

An American National Standard

IEEE Guide on Terminology for Tools and Equipment to Be Used in Live Line Working

American National Standards Institute

Approved June 12, 1989

IEEE Standards Board

Approved January 3, 1989

Sponsor

**Transmission and Distribution Committee of the
of the**

IEEE Power Engineering Society

Copyright 1989 by **The Institute of Electrical and Electronics Engineers, Inc 345 East 47th Street, New York, NY 10017, USA**

No part of this publication may be reproduced in any form, in an electronic retrieval system or otherwise, without the prior written permission of the publisher.

IEEE Standards documents are developed within the Technical Committees of the IEEE Societies and the Standards Coordinating Committees of the IEEE Standards Board. Members of the committees serve voluntarily and without compensation. They are not necessarily members of the Institute. The standards developed within IEEE represent a consensus of the broad expertise on the subject within the Institute as well as those activities outside of IEEE which have expressed an interest in participating in the development of the standard.

Use of an IEEE Standard is wholly voluntary. The existence of an IEEE Standard does not imply that there are no other ways to produce, test, measure, purchase, market, or provide other goods and services related to the scope of the IEEE Standard. Furthermore, the viewpoint expressed at the time a standard is approved and issued is subject to change brought about through developments in the state of the art and comments received from users of the standard. Every IEEE Standard is subjected to review at least once every five years for revision or reaffirmation. When a document is more than five years old, and has not been reaffirmed, it is reasonable to conclude that its contents, although still of some value, do not wholly reflect the present state of the art. Users are cautioned to check to determine that they have the latest edition of any IEEE Standard.

Comments for revision of IEEE Standards are welcome from any interested party, regardless of membership affiliation with IEEE. Suggestions for changes in documents should be in the form of a proposed change of text, together with appropriate supporting comments.

Interpretations: Occasionally questions may arise regarding the meaning of portions of standards as they relate to specific applications. When the need for interpretations is brought to the attention of IEEE, the Institute will initiate action to prepare appropriate responses. Since IEEE Standards represent a consensus of all concerned interests, it is important to ensure that any interpretation has also received the concurrence of a balance of interests. For this reason IEEE and the members of its technical committees are not able to provide an instant response to interpretation requests except in those cases where the matter has previously received formal consideration.

Comments on standards and requests for interpretations should be addressed to:

Secretary, IEEE Standards Board
445 Hoes Lane, P.O. Box 1331
Piscataway, NJ 08855-1331
USA

IEEE Standards documents are adopted by the Institute of Electrical and Electronics Engineers without regard to whether their adoption may involve patents on articles, materials, or processes. Such adoptions does not assume any liability to any patent owner, nor does it assume any obligation whatever to parties adopting the standards documents.
--

Foreword

(This Foreword is not a part of ANSI/IEEE Std 935-1989, IEEE Guide on Terminology for Tools and Equipment to Be Used in Live Line Working.)

This standard has been prepared by IEC Technical Committee No. 78: Tools for Live Line Working.

A first draft of this document was discussed during the inaugural meeting of this Technical Committee held in Paris in 1976.

Drafts were discussed at the meetings held in Stockholm in 1978, in Budapest in 1979, and in Philadelphia in 1980. As a result of the latter meeting, a draft, Document 78 (Central Office) 4, was submitted to the National Committees for approval under the Six Months' Rule in February, 1980.

Amendments, Document 78 (Central Office) 7, were submitted to the National Committees under the Two Months' Procedure for approval in April, 1981.

The National Committees of the following countries voted explicitly in favor of publication:

Argentina	Egypt	Norway
Australia	Finland	Poland
Austria	France	South Africa (Republic of)
Belgium	Germany	Spain
Bulgaria	Ireland	Sweden
Canada	Israel	Turkey
China	Japan	USSR
Denmark	New Zealand	USA

The advisory group to the US National Committee of IEC Technical Committee No. 78 is the Engineering in the Safety, Maintenance, and Operation of Lines (ESMOL) Subcommittee of the Transmission and Distribution Committee, IEEE Power Engineering Society. Members of the Working Group on Definitions, Standards, Bibliography, and Terminology of the ESMOL Subcommittee were the following:

K. E. Lindsey, *Chair*
J. M. Van Name, *Vice Chair*

F. C. Buchholz	W. H. Cole	F. D. Myers
A. A. Chase*	N. Kolcio	J. R. Volk

*Chairman, 1977-1983

The following persons were on the balloting committee that approved this document for submission to the IEEE Standards Board:

L. A. Belfore	I. S. Grant	D. T. Michael
J. J. Burke	J. G. Kapperman	F. D. Myers
V. L. Chartier	John Lapp	D. L. Nickel
W. H. Cole	J. H. Mallory	S. Nilsson
C. C. Diemond	P. S. Maruvada	J. Reeve
G. V. Fantozzi	T. J. McDermott	L. L. Smith

When the IEEE Standards Board approved this standard on January 3, 1989, it had the following membership:

Donald C. Fleckenstein, *Chair*
Marco Migliaro, *Vice Chair*
Andrew G. Salem, *Secretary*

Arthur A. Blaisdell	John W. Horch	L. Bruce McClung
Fletcher J. Buckley	Jack M. Kinn	Donald T. Michael*
James M. Daly	Frank D. Kirschner	Richard E. Mosher
Stephen R. Dillon	Frank C. Kitzantides	L. John Rankine
Eugene P. Fogarty	Joseph L. Koepfinger*	Gary S. Robinson
Jay Forster*	Irving Kolodny	Frank L. Rose
Thomas L. Hannan	Edward Lohse	Helen M. Wood
Kenneth D. Hendrix	John E. May, Jr.	Karl H. Zaininger
Theodore W. Hissey, Jr.	Lawrence V. McCall	Donald W. Zipse

*Member emeritus

Contents

1. Introduction	1
1.1 Scope	1
1.2 General Terms	1
2. Insulating Sticks	3
2.1 Hand Sticks	3
2.2 Support Sticks	8
3. Universal Tool Fittings	11
3.1 Splined End-Tools	11
3.2 Clevis and Tongue Tools	21
4. Insulating Covers and Similar Assemblies	23
4.1 Shaped Covers	23
4.2 Blanket (Flexible Cover)	26
5. Bypassing Equipment	26
5.1 Shunting Equipment	26
5.2 Shunt	27
6. Small Individual Hand Tools	28
6.1 Insulating Equipment	28
6.2 Insulated Equipment	30
7. Personal Equipment	35
7.1 Mechanical Protection	35
7.2 Electrical Protection	36
7.3 Miscellaneous	38
8. Equipment for Positioning a Worker	39
8.1 Body Belt	39
8.2 Bucket Truck with Insulating Boom	39
8.3 Extension Ladder	40
8.4 Girder Saddle Suspension Attachment	40
8.5 Hook Ladder	40
8.6 Insulating Ladder	41
8.7 Ladder Extension	41
8.8 Platform	41
8.9 Platform Pivot Attachment	42
8.10 Seat	42
8.11 Spliced Ladder	43
8.12 Triangular Beam	43

9. Handling and Anchoring Equipment	44
9.1 Rope, Sling, Rope Block, and Accessories	44
9.2 Yokes and Accessories	45
9.3 Gin	47
9.4 Saddles and Accessories	50
9.5 Miscellaneous	53
10. Measuring and Testing Equipment	55
10.1 Mechanical Measurements	55
10.2 Electrical Measurements	57
11. Hydraulic and Miscellaneous Equipment	59
11.1 Hydraulic Equipment	59
11.2 Miscellaneous Equipment	60

IEEE Guide on Terminology for Tools and Equipment to Be Used in Live Line Working

1. Introduction

1.1 Scope

This standard applies to terminology for tools and equipment used in live line working. This standard is not intended to be a dictionary giving detailed definitions of all the terms used in live line working, but only the necessary details, without indications of their components and their methods of use, to permit identification of the tools and equipment and to standardize their names.

Terms used in this guide represent the terms normally used in North America. English terms in the IEC Publication 743 (1983), Terminology for Tools and Equipment to Be Used in Live Working, will typically use the word *pole* instead of *stick* and *tenon* instead of *tongue*. It should also be noted that there are other tools available and presently in use that are not shown in this guide.

1.2 General Terms

1.2.1 Difference between Insulated and Insulating Tools

1.2.1.1 Insulated Tool

A tool made of conductive material and fully or partly covered by insulating material.

1.2.1.2 Insulating Tool

A tool essentially made of insulating material.

1.2.2 Insulating Tool Components

1.2.2.1 End Fitting

Part (generally metallic) permanently fitted to the ends of insulating tube or rod.

1.2.2.2 Foam

An insulating material composed of closed polyurethane cells. Its purpose is to prevent the ingress and migration of moisture.

1.2.2.3 Rod

Solid rod composed of synthetic insulating material, normally reinforced.

1.2.2.4 Tube

Composed of synthetic insulating material, normally reinforced, the interior of which may be filled or hollow.

1.2.3 Types of Tools and Insulating Assemblies

1.2.3.1 Auxiliary Arm Assembly

Support tools arranged to form an auxiliary arm, to lift conductors off their insulators.

1.2.3.2 Hand Stick

Used to operate on network components at a distance. It is subjected only to the loads imposed by the worker.

Examples:

- 1) universal hand stick
- 2) wire cutting stick

1.2.3.3 Insulating or Insulated Hand Tools

Constructed of insulating material or of conductive material (e.g., metal) primarily for mechanical strength, and then coated or covered with insulating material to protect the worker from electrical contact and to avoid flashovers.

1.2.3.4 Mast Assembly

Various support sticks and tools arranged in a swivel-boom-type configuration assembled in place on a structure that, for example, may be used to

- 1) lift a string of insulators out of their position to facilitate changing damaged units;
- 2) lift Conductors off their insulators.

1.2.3.5 Support Stick

Used to hold or move conductors and equipment.

Examples:

- 1) tension stick
- 2) suspension link stick
- 3) conductor support stick
- 4) swivel boom

1.2.3.6 Trolley Roll Layout

Various support tools assembled with support stricks, saddles, trolley wheels, pole-clamps, and insulator forks.

1.2.3.7 Working Stick

Consists of insulating tube and/or rod with end fittings.

The two types are

- 1) hand stick
- 2) support stick

1.2.4 Tools and Accessories

Tools and accessories that can be attached to the end fitting of universal sticks and that are used to perform various operations.

1.2.5 Protective Covers

Generally made of insulating materials, they are used to cover live or non-energized elements in order to avoid accidental contact.

They may be rigid or flexible and either shaped or in sheets.

2. Insulating Sticks

2.1 Hand Sticks

2.1.1 All-Angle Cog Wrench

Used with removable sockets to install and remove bolts and nuts.

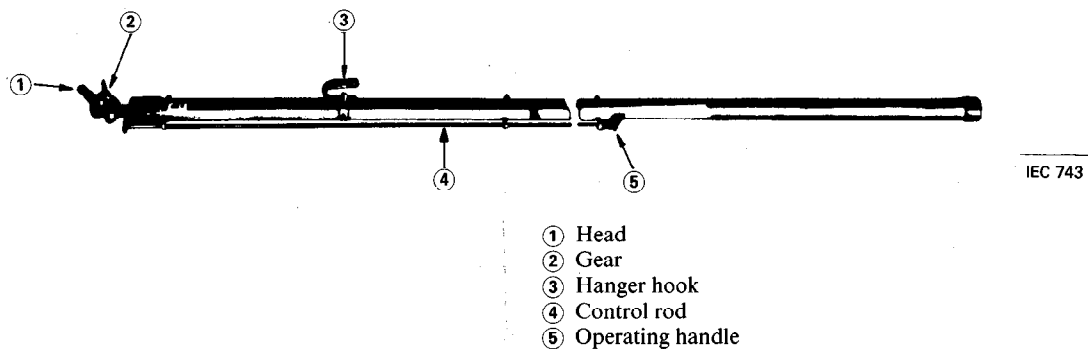

2.1.2 Clip-on Ammeter Stick

A tool to which a clip-on ammeter is attached.

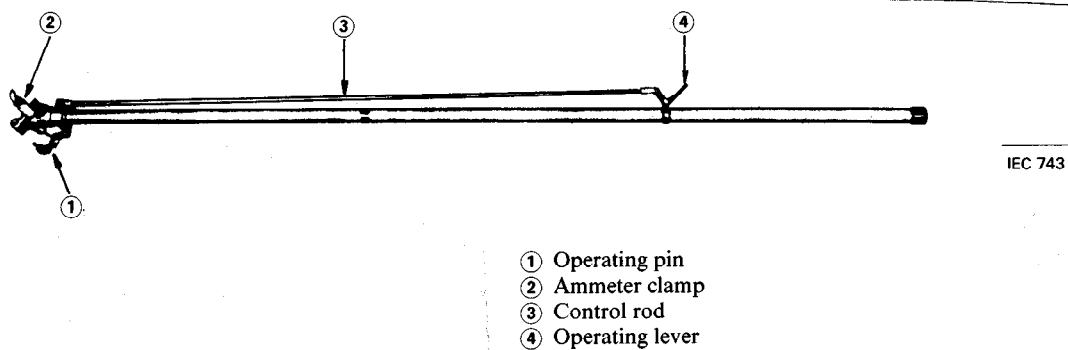

2.1.3 Cotter Key Plier Stick

Used to grip, hold in place, or remove various small pieces.

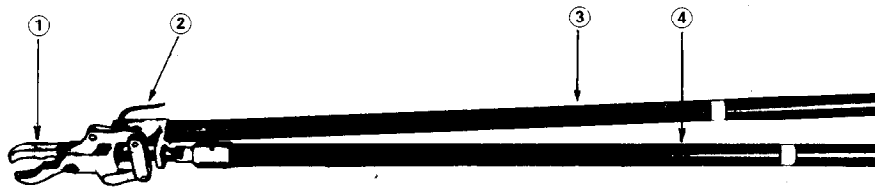

IEC 743

- ① Jaw
- ② Hanger hook
- ③ Support handle
- ④ Operating handle

2.1.4 Flexible Insulated Wrench

Used with removable sockets to hold, install, and remove bolts and nuts.



IEC 743

- ① Flexible socket wrench head
- ② Universal splined-head

2.1.5 Insulating Oiler Stick

Used to apply a lubricant or rust penetrant.

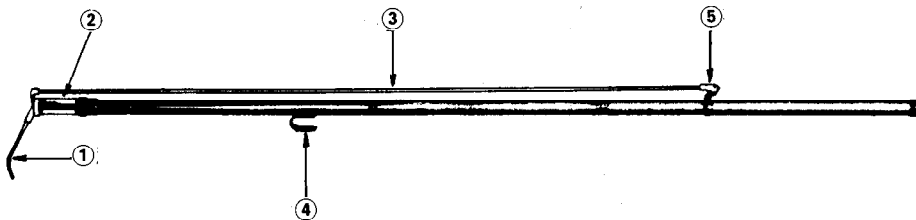

IEC 743

- ① Spout
- ② Oil reservoir
- ③ Control rod
- ④ Hanger hook
- ⑤ Operating handle

2.1.6 Retractable Hook Stick

Used to install, remove, or handle live-line clamps and various accessories equipped with an eye.

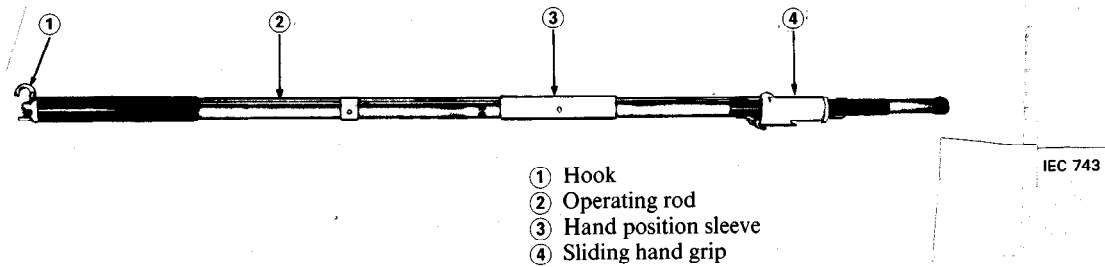

2.1.7 Retractable Hook Stick Extension

Attached to the retractable hook stick to provide a longer reach.

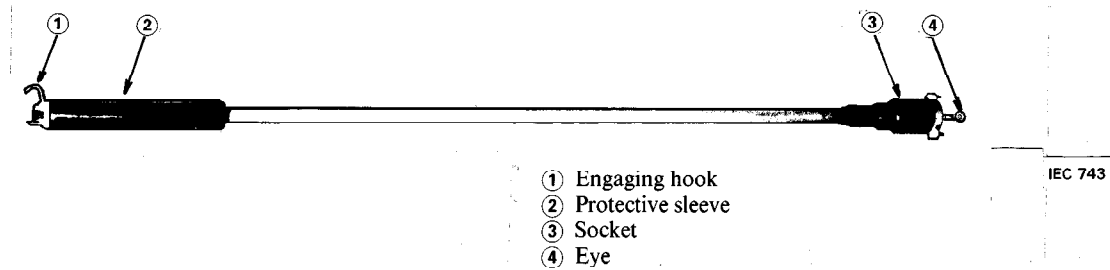

2.1.8 Spliced Universal Hand Stick

Made of one or more elements spliced together.

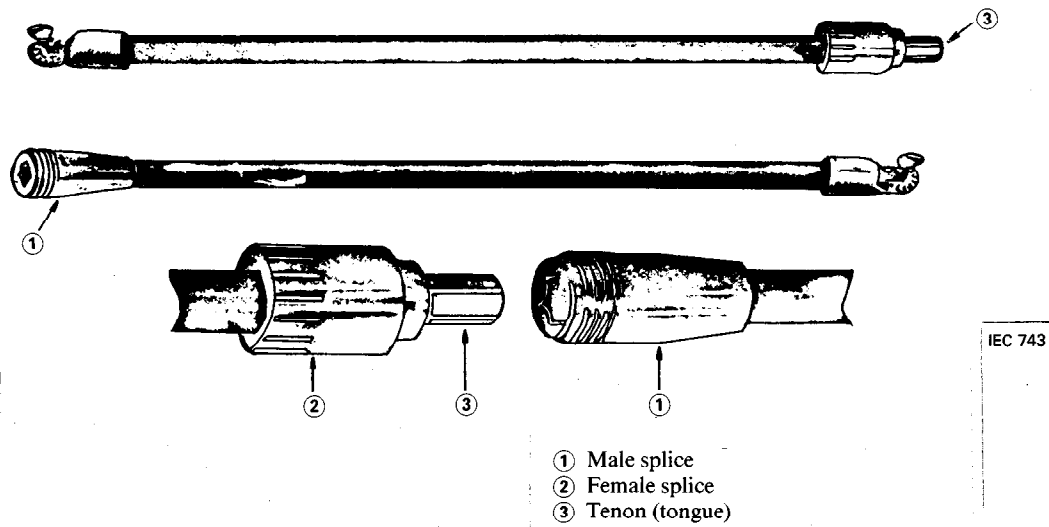

2.1.9 Tie Stick

Used to install or remove tie wires.

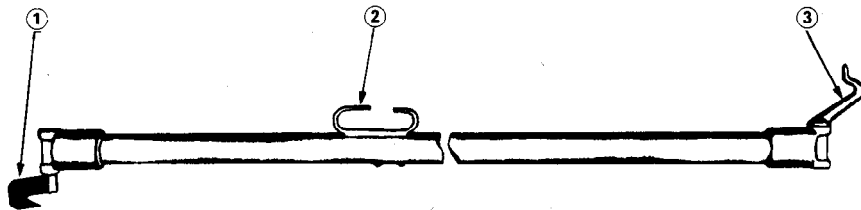

IEC 743

- ① Rotary blade
- ② Combination hanger-hook and tie-wire
- ③ Rotary prong

2.1.10 Tie Wire Cutter

Used to cut tie wires.

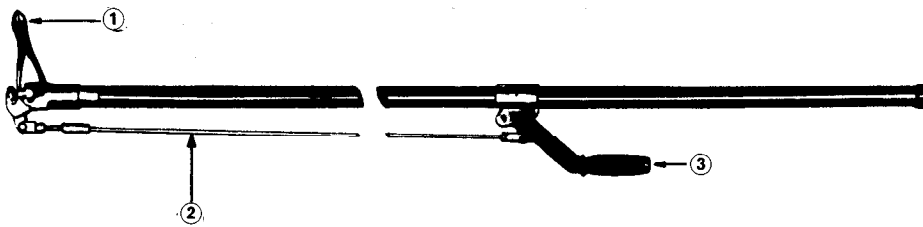

IEC 743

- ① Cutting plier
- ② Control rod
- ③ Operating lever

2.1.11 Universal Hand Stick

A tool to the end of which universal tools can be attached.

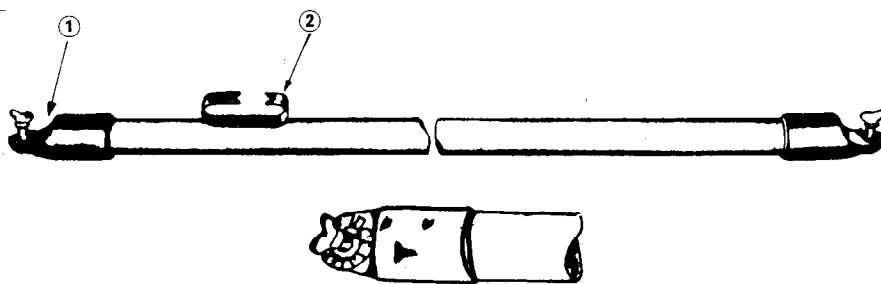

IEC 743

- ① Splined end-fitting
- ② Combination hanger-hook and tie-wire

2.1.12 Wire Cutter Stick

Used to cut conductors or blinding wires.

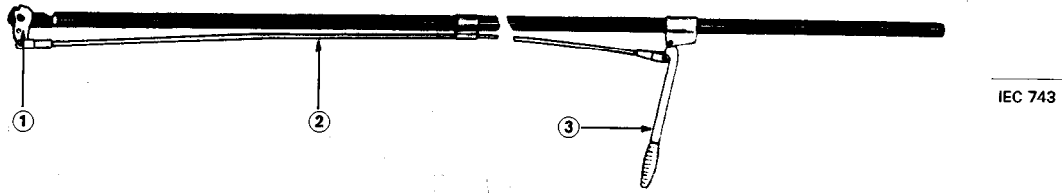

IEC 743

- ① Cutting head
- ② Control rod
- ③ Operating handle

Lever-type (light duty)

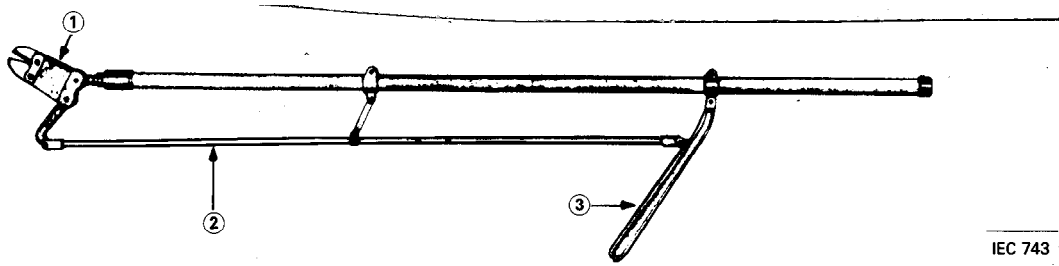

IEC 743

- ① Cutting head
- ② Control rod
- ③ Operating handle

Lever-type (medium duty)

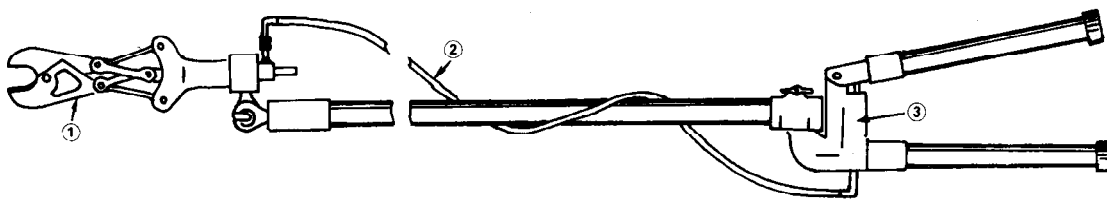

IEC 743

- ① Cutting head
- ② Flexible hose
- ③ Hydraulic pump

Hydraulic

2.1.13 Wire Holding Stick

Used to hold conductors or wire during operations.

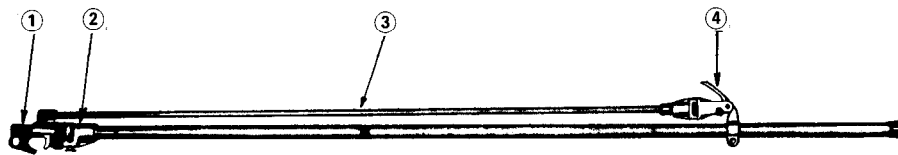

- ① Adjustable jaw
- ② Adjustable tilting head
- ③ Control rod
- ④ Locking lever

IEC 743

2.2 Support Sticks

2.2.1 Adjustable Strain Stick

A support tool that, with various accessories, can be used to lift or tension wires.

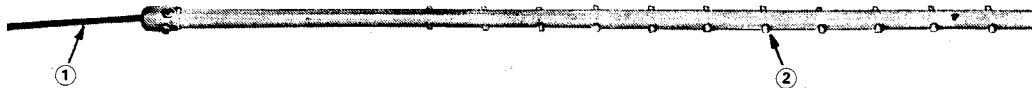

- ① Screw
- ② Metal adjustment-pin

IEC 743

2.2.2 Clevis/Tongue Stick

A support tool used with appropriate attachment and/or adapters to perform various operations.



- ① Clevis
- ② Tenon (tongue)

IEC 743

2.2.3 Deadend Tool

Used to hold the tension of a conductor, in order to replace a deadend string of insulators.

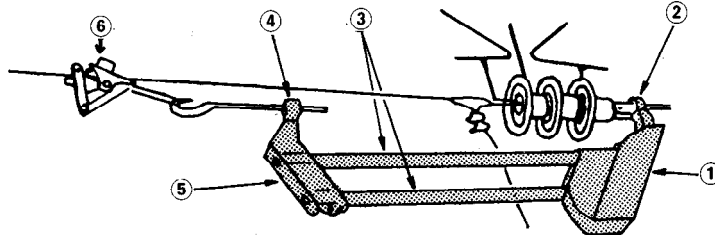

IEC 743

- ① Flange (with insulated cover)
- ② Hook
- ③ Poles (sticks)
- ④ Jacking-screw
- ⑤ Flange
- ⑥ Automatic come-along clams (wire grips)

2.2.4 Roller Link Stick

A link stick equipped with a roller that allows its movement along the conductor.

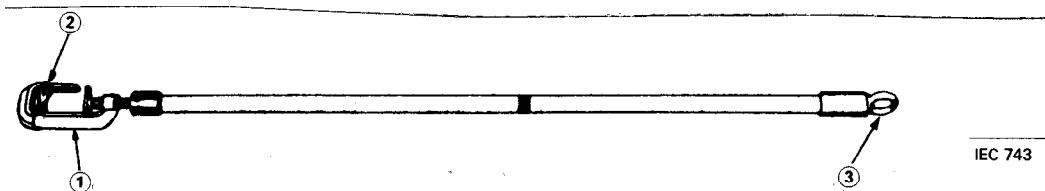

IEC 743

- ① Head
- ② Roller
- ③ Swivel eye (butt-ring)

2.2.5 Spiral Link Stick

A tension link stick equipped with a spiral link at one end.

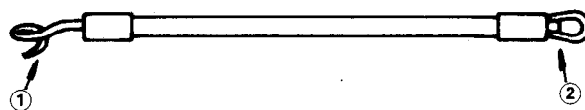

IEC 743

- ① Spiral link
- ② Swivel eye (butt-ring)

2.2.6 Swivel Link Stick

A tension link stick equipped with a swivel eye at one or both ends.

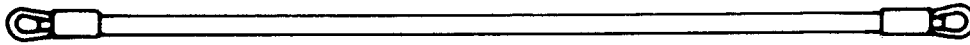

IEC 743

2.2.7 Tension Link Stick

Used to apply tension to a component (or conductor).

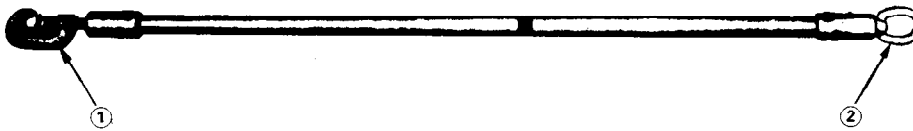

IEC 743

- ① Jaws
- ② Swivel eye (butt-ring)

2.2.8 Wire Support Stick

Used to position or move a conductor.

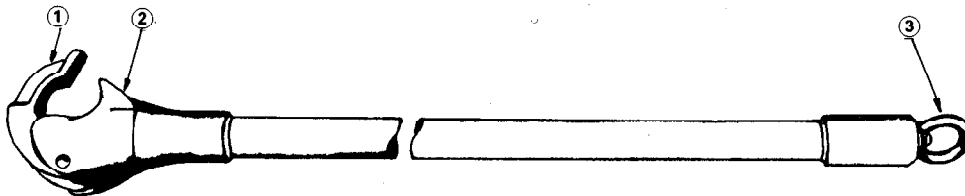

IEC 743

- ① Movable jaw
- ② Fixed jaw
- ③ Swivel eye (butt-ring)

3. Universal Tool Fittings

3.1 Splined End-Tools

3.1.1 Adjustable Insulator Fork

Used to control insulators during their installation or removal. May have insulated adjustable jaws.

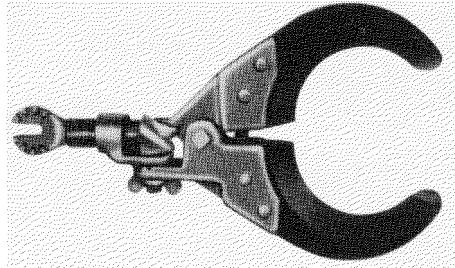

3.1.2 Adjustable Pliers

Used to grip small parts.

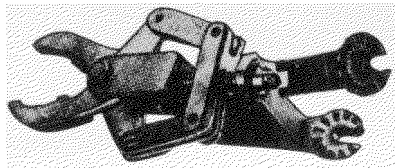

3.1.3 All-Angle Pliers

Used to hold various loose parts adjustable to various angles.

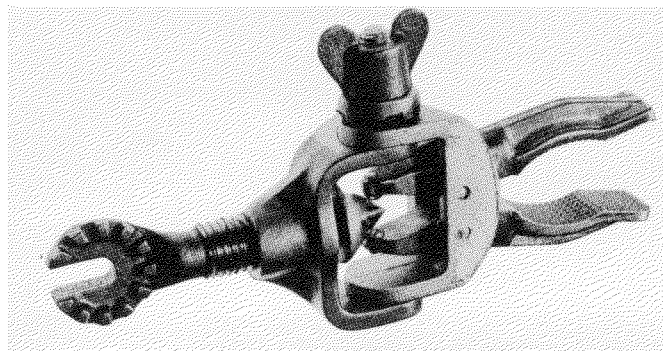

3.1.4 Ammeter Holder

Used to hold a clip-on ammeter.

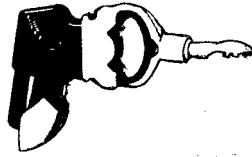

3.1.5 Anti-Interference Braid Applicator

Used to install antistatic braids between the pin of the insulator and the conductor clamp.

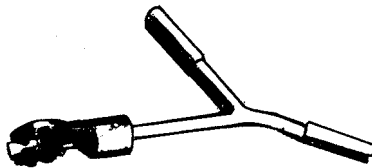

3.1.6 Ball Socket Adjuster

Used to hold a ball socket during connection and disconnection.

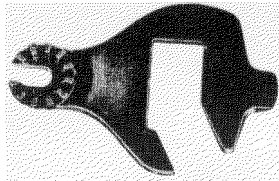

3.1.7 Conductor Cleaning Brush

Used to clean conductors.

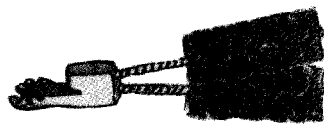

V-shaped

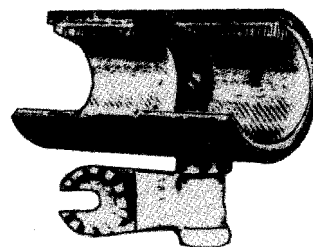

Semi-tubular

3.1.8 Conductor Sander

Used to polish the conductor surface.



3.1.9 Cotter Key Installer

Used to install split pins, cotter keys, etc.

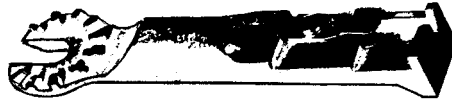

3.1.10 Cotter Key Installer-Remover

Used to install or remove split pins, cotter keys, etc.

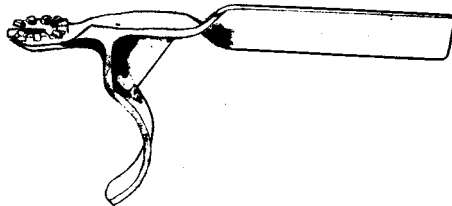

3.1.11 Cotter Key Remover

Used to pull cotter keys from fittings or hardware.



Spiral type

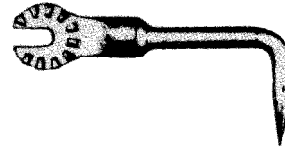

Fine-point type



Cam type (pry type)



Snap-out type

3.1.12 Fixed Double-Prong Head

Used to manipulate tie wire or equipment.

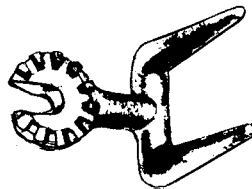

3.1.13 Flexible Wrench Head

Used with removable socket to tighten or loosen nuts and bolts.

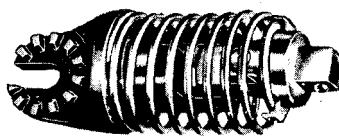

3.1.14 Formed Wire Tool

Used to install and remove formed or pre-formed tie wire.

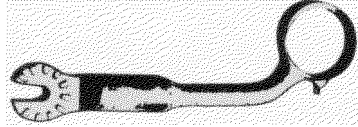

3.1.15 Hack Saw

Used for sawing any metal part.

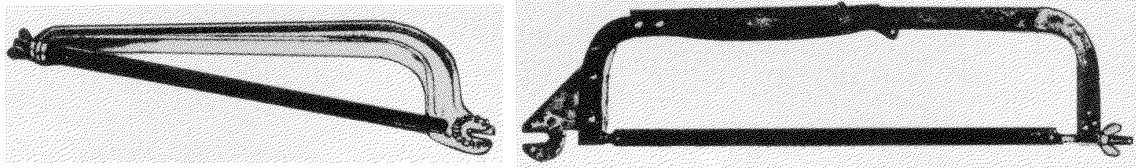

3.1.16 Hammer

Used to impact equipment as required.

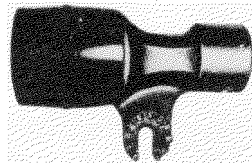

3.1.17 Holding Fork.

Used to hold components in position when using other tools.

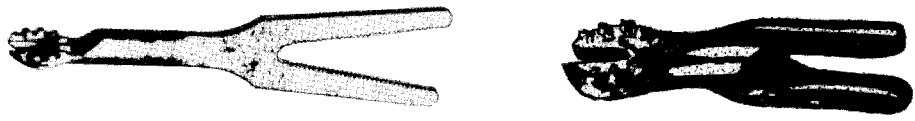

3.1.18 Insulator Ball Guide

Used to engage or disengage the ball of a ball socket fitting.

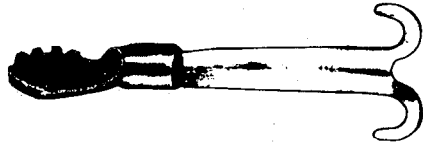

3.1.19 Locating Drift

Used to align two holes or to push a pin.

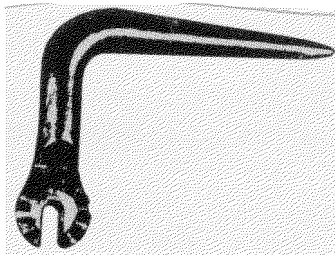

3.1.20 Mechanical Hand

Used as a hand as pliers for forming tie wires.

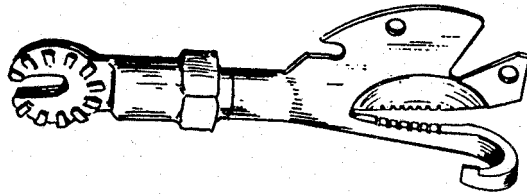

3.1.21 Mirror

Attached to a universal hand stick; used to inspect parts that are not directly visible.



EQUIPMENT TO BE USED IN LIVE LINE WORKING

3.1.22 Oilcan

Used to apply a lubricant or rust penetrant.

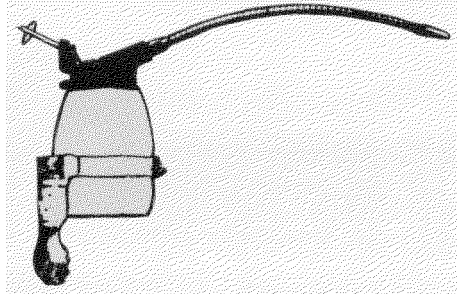

3.1.23 Pin Holder

Used to hold a pin.



3.1.24 Positive Grip Clamp Stick Head

Used to hold any component equipped with an eye.

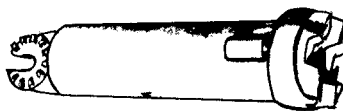

3.1.25 Pruning Saw

Used to trim tree branches.

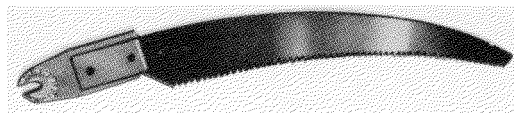

3.1.26 Ratchet Wrench

Used with removable sockets to tighten or loosen nuts and bolts.

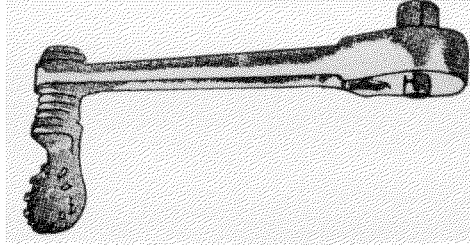

3.1.27 Retractable Hook Stick Adaptor

Device used to adapt a retractable hook stick to permit the attachment of universal accessories.

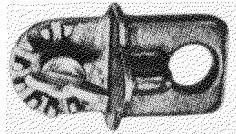

3.1.28 Rotary Blade

Used to manipulate tie wires.

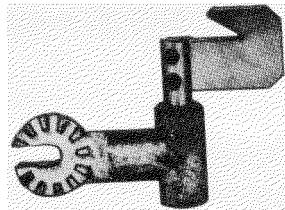

3.1.29 Rotary Prong

Used to manipulate tie wires or insulating blankets.

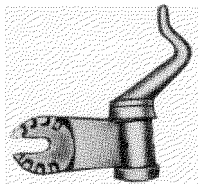

3.1.30 Screw Clamp

Used to grip and position an insulator cap by its adjustable jaws.

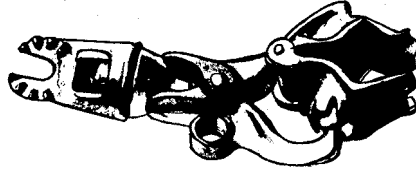

3.1.31 Screwdriver

Used to tighten or loosen screws.

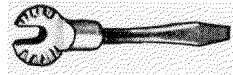

3.1.32 Self-aligning Fuse Puller

Used to grip, remove, and install fuses.

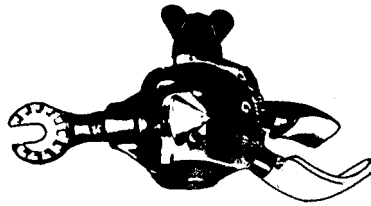

3.1.33 Shepherd's Hook

Used to guide insulators.

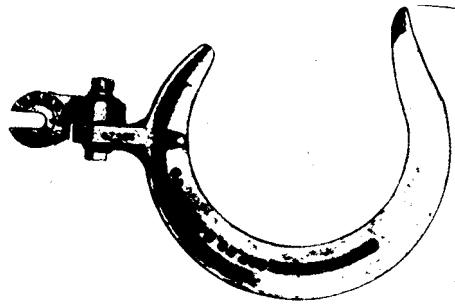

3.1.34 Spiral Disconnect

Used to handle various types of equipment fitted with eyes.

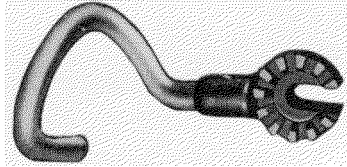

3.1.35 Tie Wire Cutter

Used to snap tie wire.



3.1.36 Universal Adaptor

Used to change the angle of attachment on a universal hand stick.

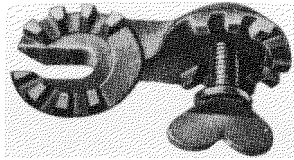

3.1.37 Vice Grip Pliers

Used to hold various parts.

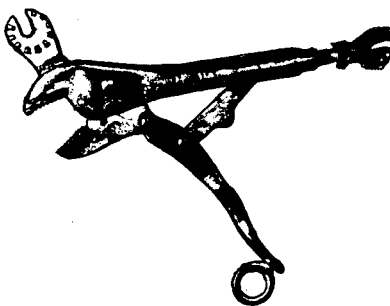

3.1.38 Wrench

Used to hold nuts and bolts.



3.2 Clevis and Tongue Tools

3.2.1 Clevis Eye Attachment

Used to convert a tongue stick into a support stick.

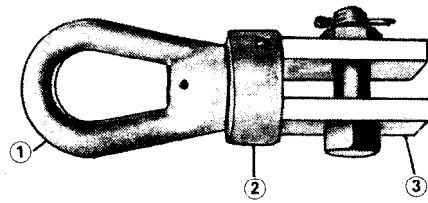

- ① Eye
- ② Swivel
- ③ Clevis

3.2.2 Clevis Screw Adapter

Used in conjunction with a ratchet to apply and release mechanical loads.

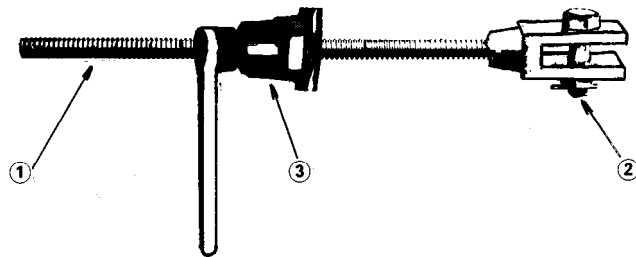

- ① Screw
- ② Clevis
- ③ Ratchet

3.2.3 Clevis-Tongue Adapter

Used to convert a clevis-tongue stick into a clevis-clevis or tongue-tongue stick.

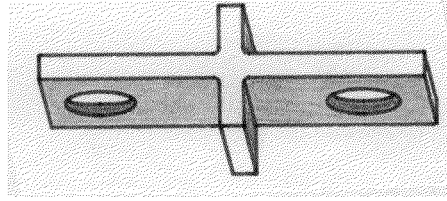
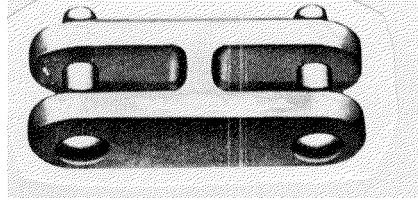

3.2.4 Clevis-Tongue Extension

Used to extend a clevis end stick.

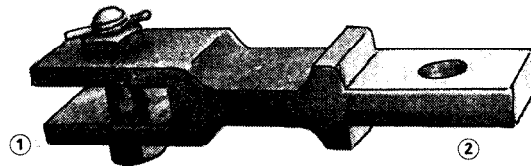

- ① Clevis
- ② Tongue attachment

3.2.5 Roller-Tongue Attachment

Used to convert a clevis-tongue stick into a roller link stick.



- ① Roller
- ② Tenon (tongue) attachment

3.2.6 Strain Link Tongue Attachment

Used to convert a clevis stick into a strain link stick.

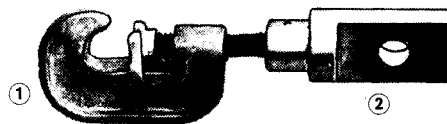

- ① Strain head
- ② Tongue attachment

4. Insulating Covers and Similar Assemblies

4.1 Shaped Covers

4.1.1 Bag

Made of insulating material to cover conductive fittings.

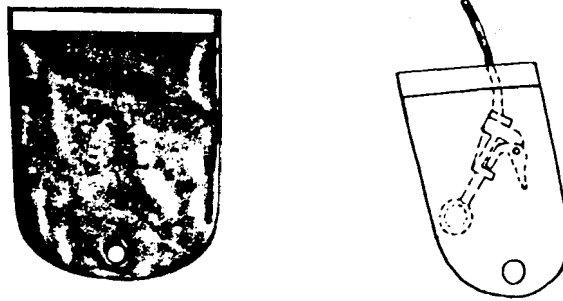

4.1.2 Barrier

Made of insulating material and generally used to limit the work zone.

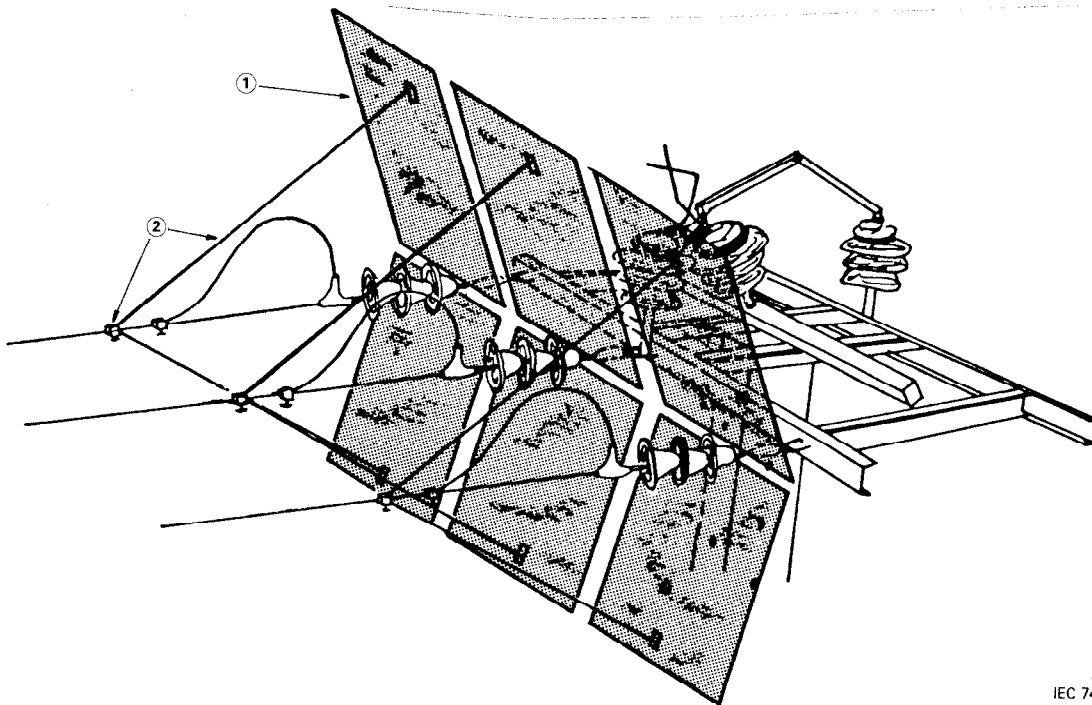

IEC 743

- ① Barrier
- ② Fixing devices

4.1.3 Conductor Cover

Made of insulating material and used to insulate conductive parts. It can be of a flexible or rigid type, according to the material used.

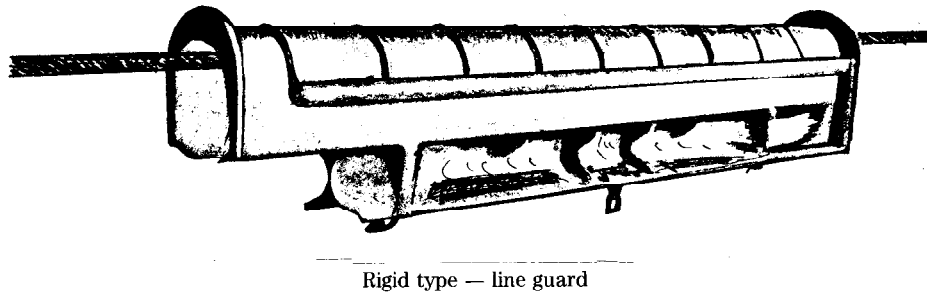
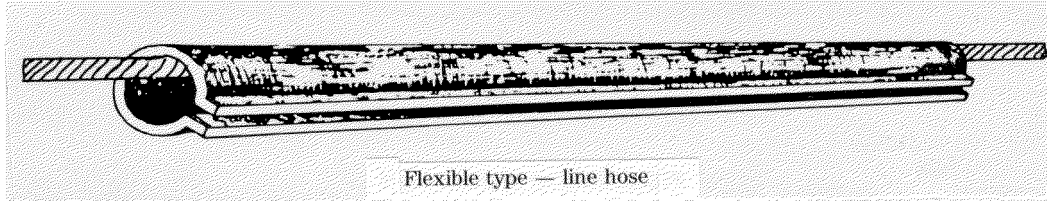

4.1.4 Dead-End Clamp Cover

Insulating cover used to cover dead-end clamps.

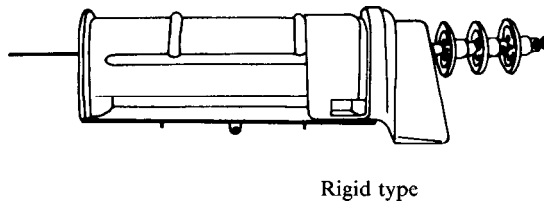

4.1.5 Dead-End Cover

Insulating cover used to cover dead ends.

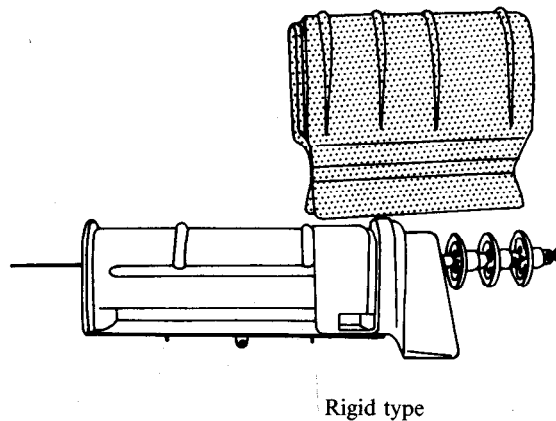

4.1.6 End-Cap.

Made of rubber or synthetic material and used to insulate the exposed ends of an insulated conductor.

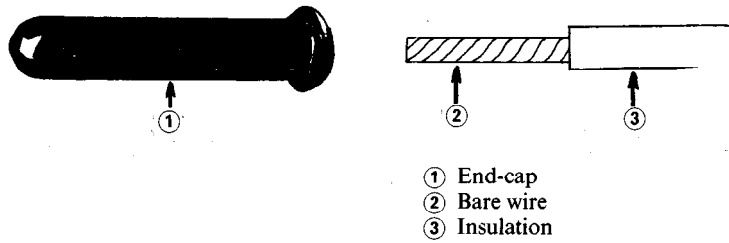

4.1.7 Pin-type Insulator Cover

Insulating cover used to cover pin-type insulators.

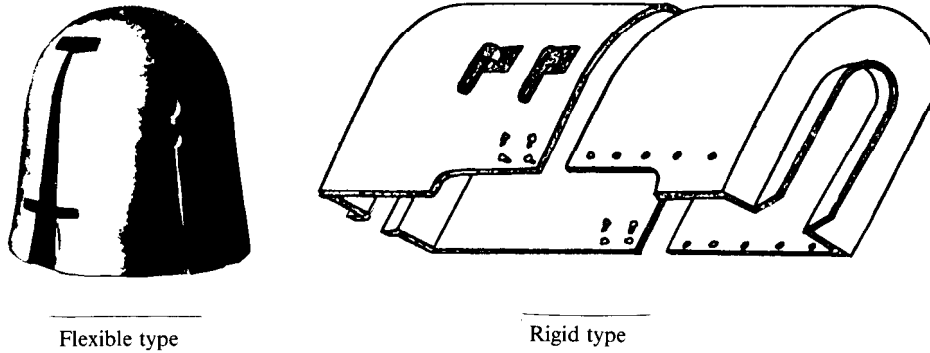

4.1.8 Suspension String Cover

Insulating cover used to cover suspension insulator strings.

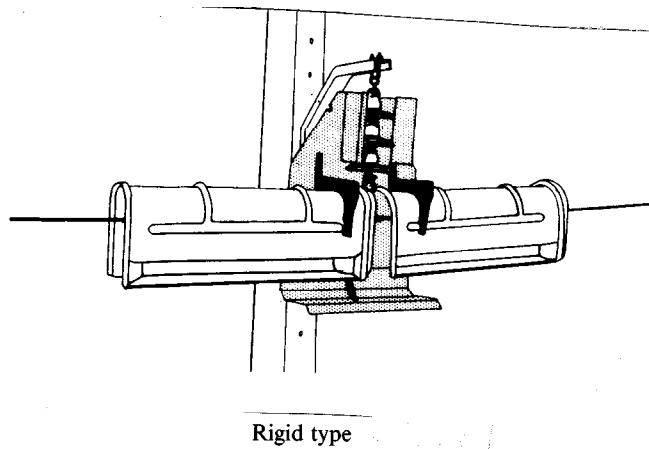

4.2 Blanket (Flexible Cover)

Made of rubber or synthetic materials, used to insulate conductors or metallic parts, energized or not.

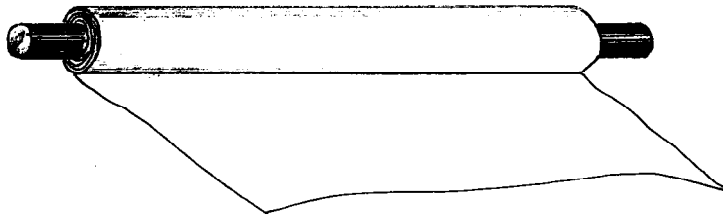
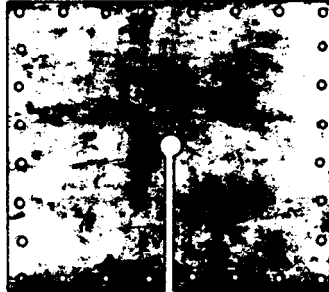

Flexible cover

5. Bypassing Equipment

5.1 Shunting Equipment

5.1.1 Loadbreak

Single-phase switch used to connect or disconnect a circuit under load.

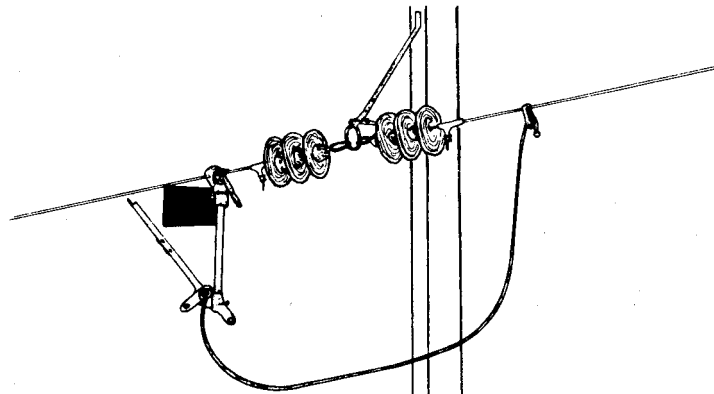

5.1.2 Shunting Fork

A metal fork fitted to an insulating stick and used to

- 1) bypass a fuse
- 2) open or close under load



5.2 Shunt

5.2.1 Bypass Jumper

Generally made of single-core insulated cable, used during the maintenance of various types of apparatus. May be covered by a rigid tube.

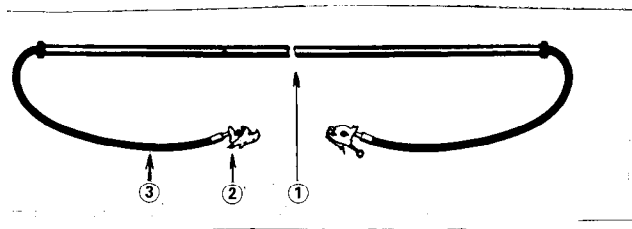

- ① Supporting tube
- ② Connector
- ③ Flexible insulated cable

IEC 743

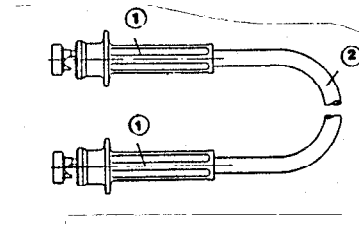

- ① Insulated clamp
- ② Jumper cable

5.2.2 Fused Bypass Jumper

Single-core insulated cable fitted with a fuse and used during the repair of a fuse or the maintenance of various types of apparatus.

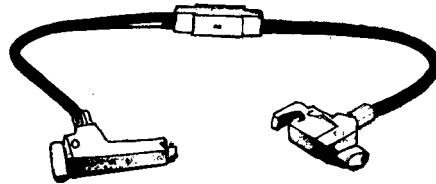

5.2.3 Load Pickup Jumper

Single-core insulated cable, fitted on one end with an insulated clamp and on the other with an insulated clamp containing contacts that can be opened or closed. The contacts can be closed to pick up a load, but it has no load break rating.

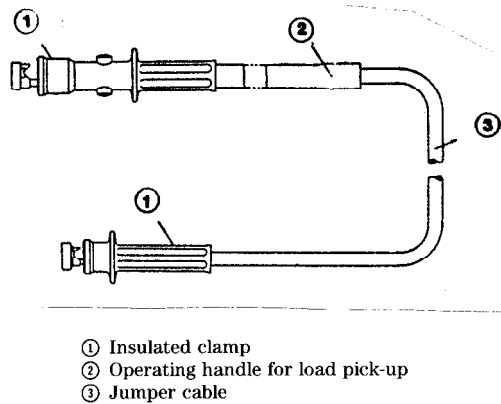

6. Small Individual Hand Tools

6.1 Insulating Equipment

6.1.1 Cutting Nipper

A tool with metal cutting edges.

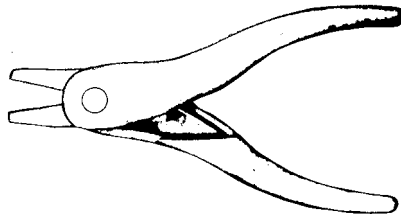

6.1.2 Flat or Round Nose Pliers

Used for handling a conductor.

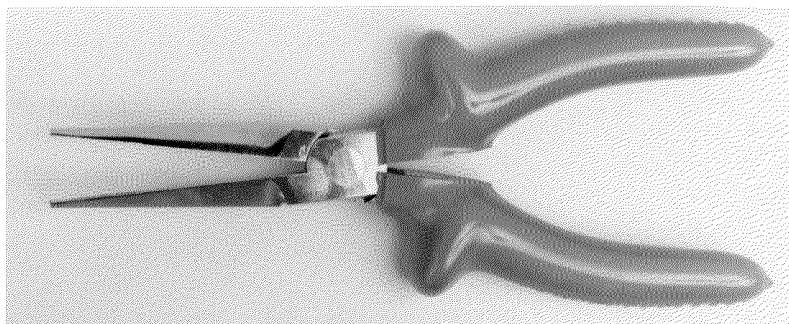

EQUIPMENT TO BE USED IN LIVE LINE WORKING

6.1.3 Lever

Used to open the sheath of cable or to pry the covering off conductors.



6.1.4 Punch

A tool with a metal point used to break solid insulating material.



6.1.5 Screwdriver

A tool with metallic end fitting, used to install and remove screws.

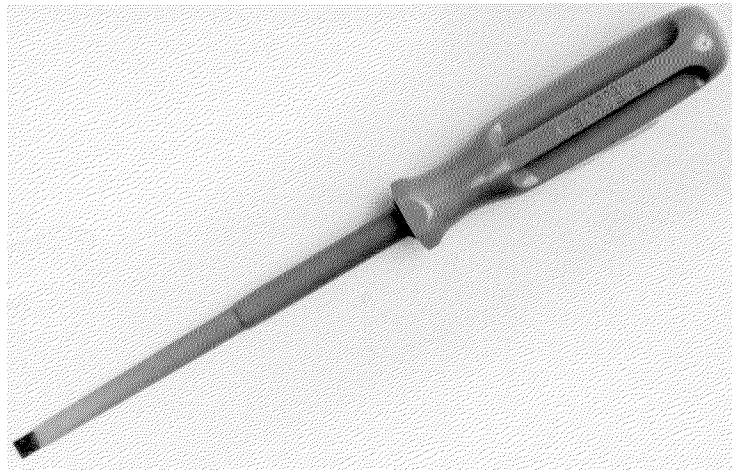

6.1.6 Wedge

Used to separate the phase conductors of a cable.

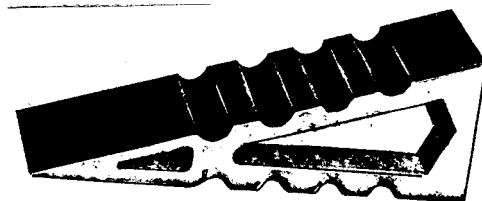

6.2 Insulated Equipment

6.2.1 Adjustable Pliers

Used to handle, tighten, or loosen various pieces.

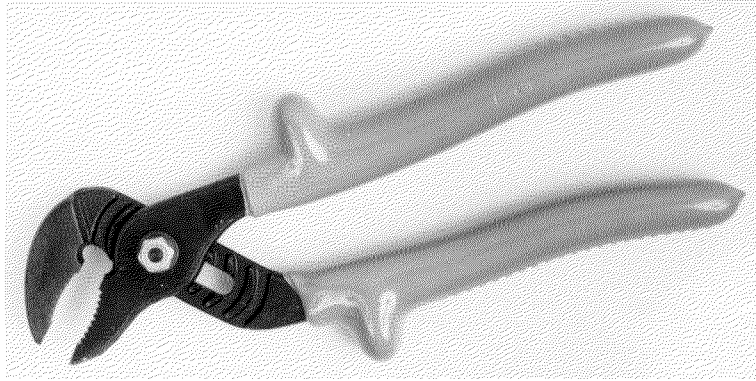

6.2.2 Adjustable Wrench, Open End

Used to tighten or loosen nuts and bolts.

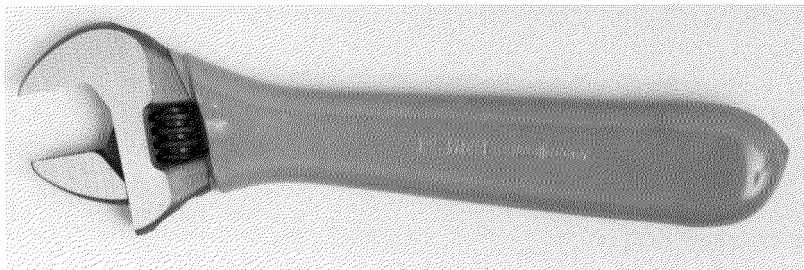

6.2.3 Cable Cutter

Used to cut cables.



6.2.4 Combination Pliers

Used to hold various pieces or to cut wire.

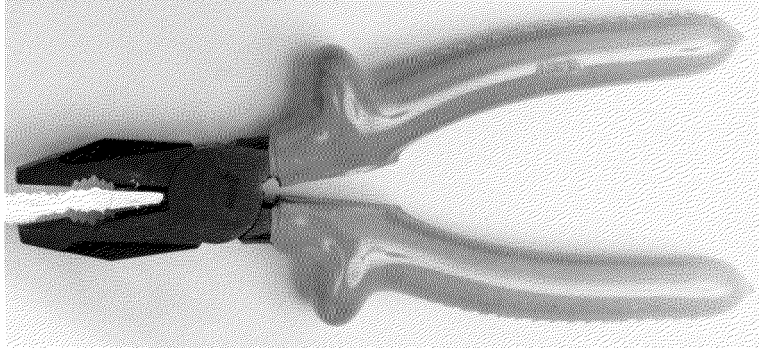

6.2.5 Cutting Nipper

Used to cut.

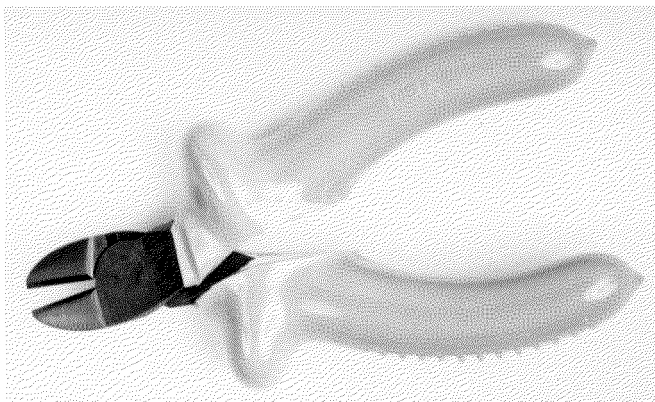

6.2.6 Open End Wrench, Single Head

Used to tighten and loosen nuts and bolts.

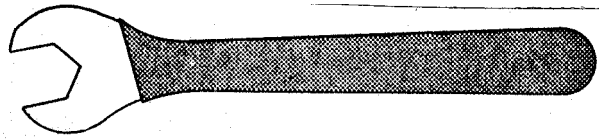
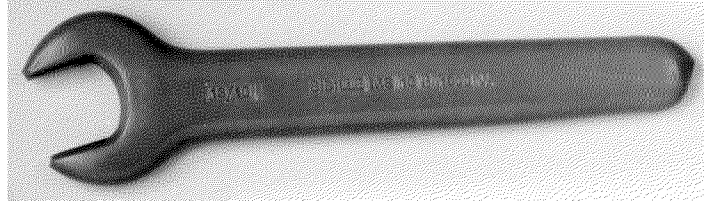

6.2.7 Extension Bar

A covered metal device made to be inserted between ratchet drive handle and socket.



6.2.8 Long-Nose Pliers with or without Side Cutter

Used to grip or tighten components, or to cut.

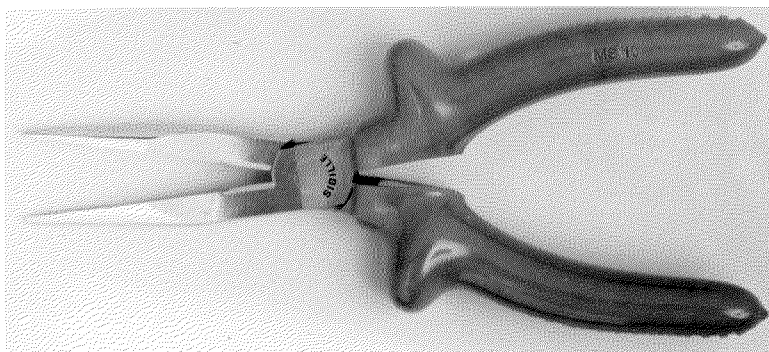

6.2.9 Ratchet Handle, Reversible or Not

Drive ratchet used to hold a socket to tighten or loosen screws, nuts, and bolts.

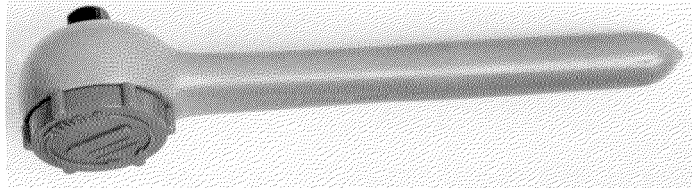

6.2.10 Box End Wrench, Single End, Deep Offset or Not

Used to tighten and loosen nuts and bolts.

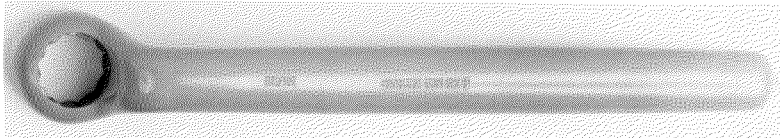

6.2.11 Round-Nose Pliers

Used to hold or bend components.

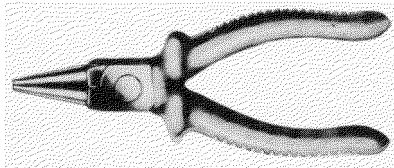

6.2.12 Screwdriver

Used to install or remove screws. It may have different shapes of ends.

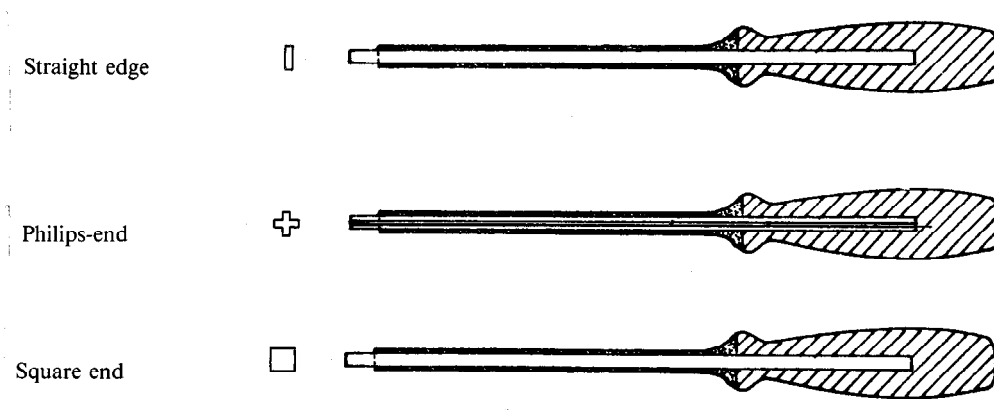

6.2.13 Nut Driver, Spin Type

Used to tighten or loosen screws, nuts, and bolts.

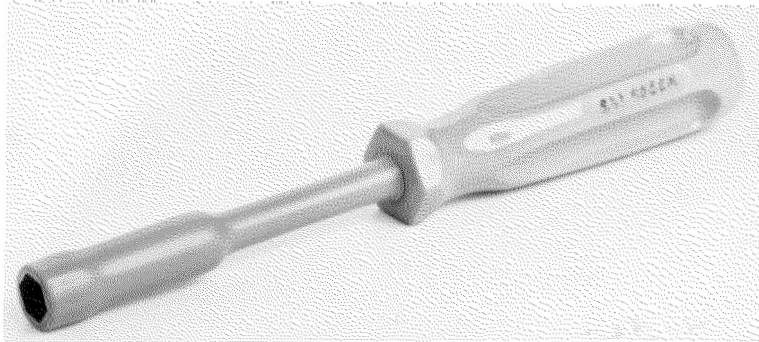

6.2.14 Stripping Knife

Used to strip insulation from conductors.



6.2.15 Tee Wrench

Used to tighten or loosen screws, nuts, and bolts.

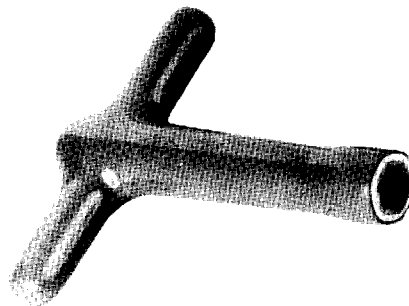

7. Personal Equipment

7.1 Mechanical Protection

7.1.1 Insulating-Glove Protector

Used for mechanical protection of insulating gloves.

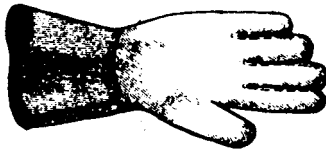

7.1.2 Safety Boots

Equipped with safety toes and toughened puncture-resistant non-slip soles.

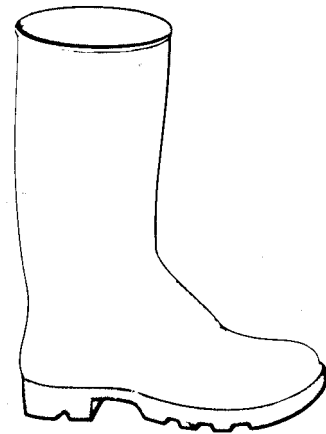

7.1.3 Safety Helmet

Made of synthetic material, equipped with a chin strap and adjustable headband.

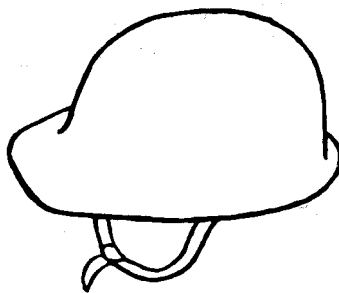

7.1.4 Safety Shoes

Equipped with safety toes and toughened puncture-resistant non-slip soles.



7.2 Electrical Protection

7.2.1 Bonding Lead

Metallic connection used by the worker to connect or disconnect his conductive clothing, grid, or screen, to or from a conductive part of an installation.

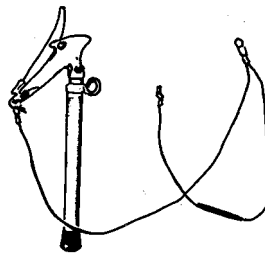

7.2.2 Conductive Clothing

Made of natural or synthetic material, interwoven with a conductive thread; used to shield workers from the effect of electric fields.

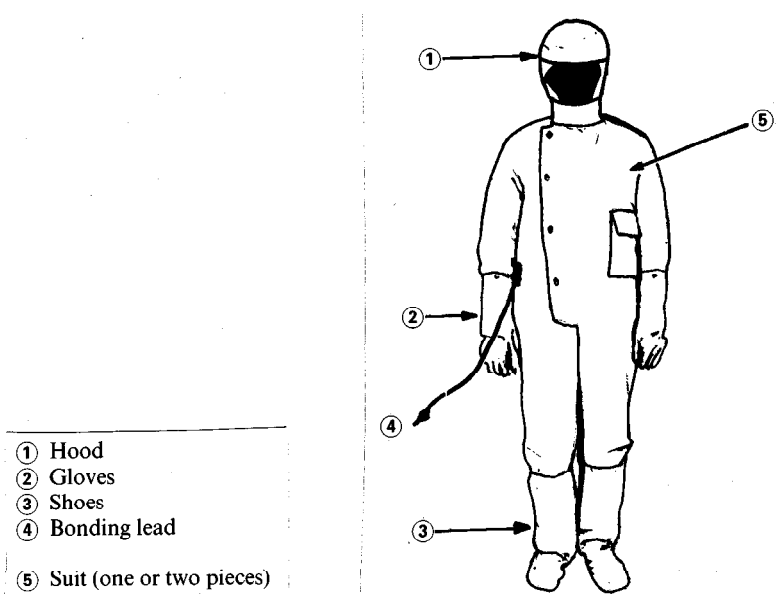

7.2.3 Insulating Arm Sleeves

Made of rubber or synthetic material, used for electrical protection of the worker's arms.

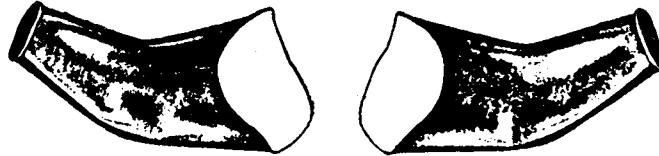

7.2.4 Insulating Boots

Made of insulating material with non-slip soles, used for the electrical protection of the worker's feet.

7.2.5 Insulating Clothing

Made of insulating material, used for electrical protection of the worker's body.

7.2.6 Insulating Gloves

Made of rubber or synthetic material, used for the electrical protection of the worker's hands.



7.2.7 Insulating Overshoes

Made of supple insulating material with non-slip soles, used for the electrical protection of the worker's feet.

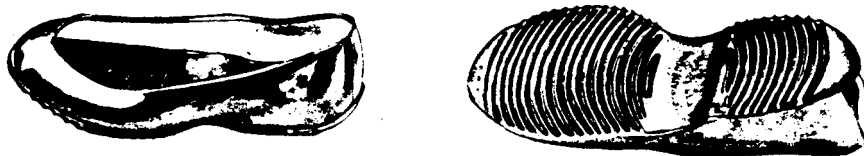

7.3 Miscellaneous

7.3.1 Face Shield

Protection for the complete face. The shield may be clear or tinted, to afford protection from ultraviolet light in the event of an electrical flash.

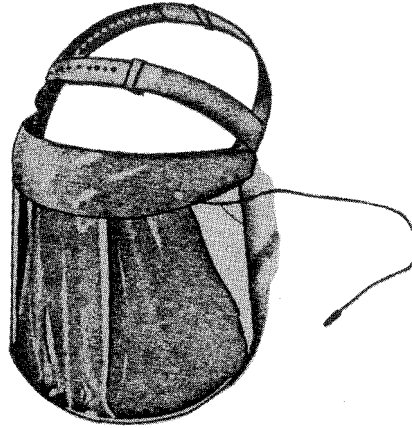

7.3.2 Safety Spectacles and Goggles.

Spectacles and goggles with shatter-proof lenses and frames of synthetic material. The lenses may be clear or tinted to afford protection from ultraviolet light in the event of an electrical flash.

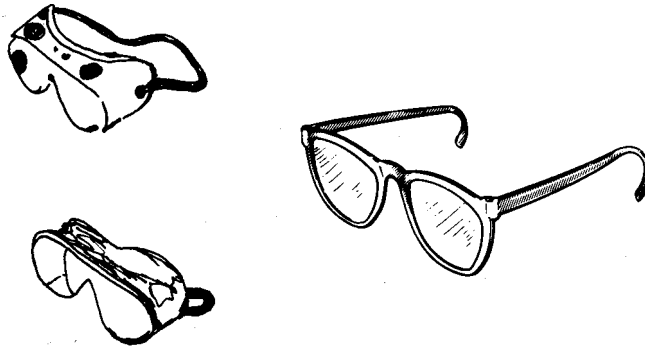

8. Equipment for Positioning a Worker

8.1 Body Belt

Made of leather or synthetic material, equipped with adjustable safety strap or a sling, or both.

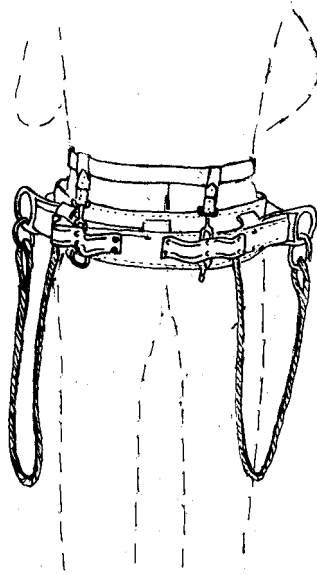

8.2 Bucket Truck with Insulating Boom

Comprising an insulating boom equipped with one or two buckets. It may be mounted on a vehicle and used to position a worker.

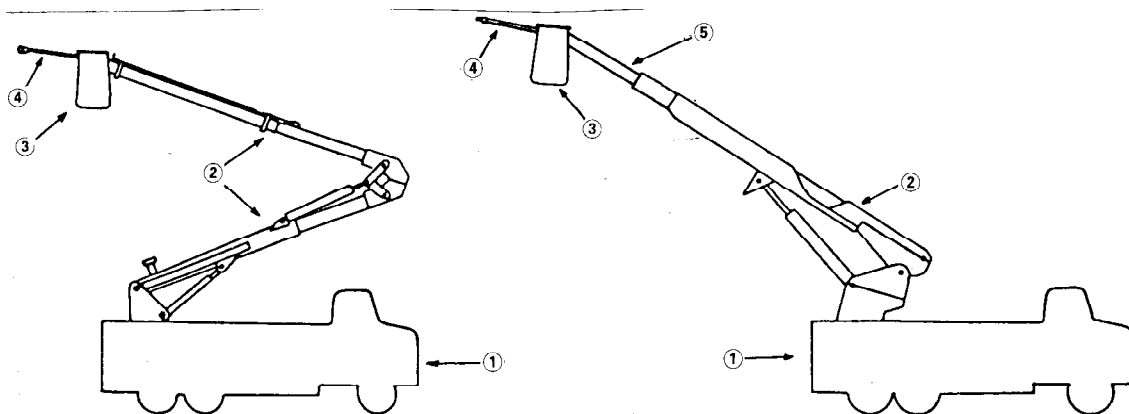

- ① Carrying vehicle
- ② Articulated arm (boom)
- ③ Bucket
- ④ Lifting arm (jib)
- ⑤ Telescopic arm (boom)

IEC 743

8.3 Extension Ladder

A ladder that can be lengthened by the use of sliding parts that fit into each other.

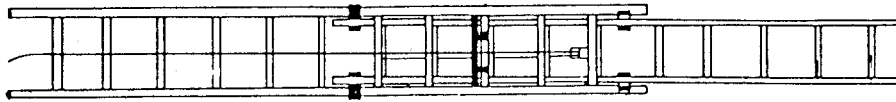

8.4 Girder Saddle Suspension Attachment

A metal accessory, attached to a structure, that is used to suspend a seat, ladder, etc.

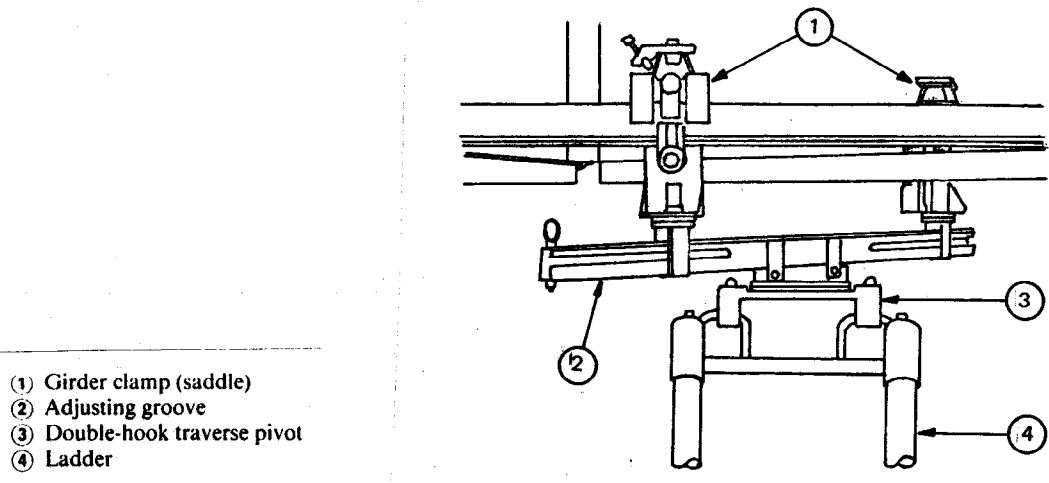

8.5 Hook Ladder

Equipped with permanent or removable hooks that can be rigid or rotatable.

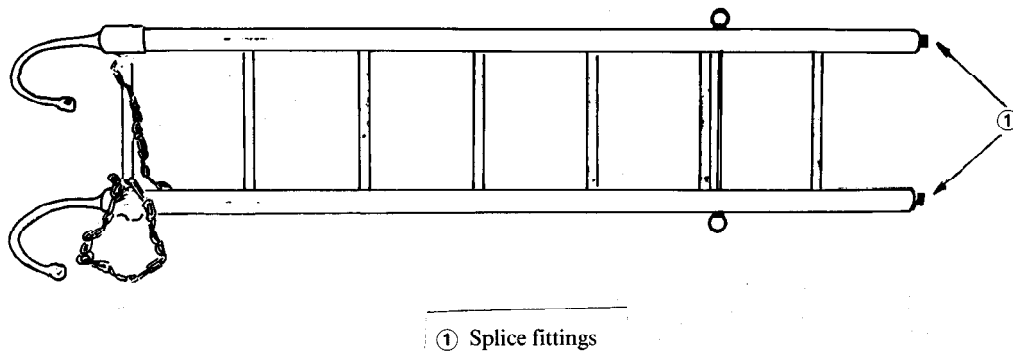

8.6 Insulating Ladder

Made of insulating material.

8.7 Ladder Extension

An additional section that can be spliced to another ladder.

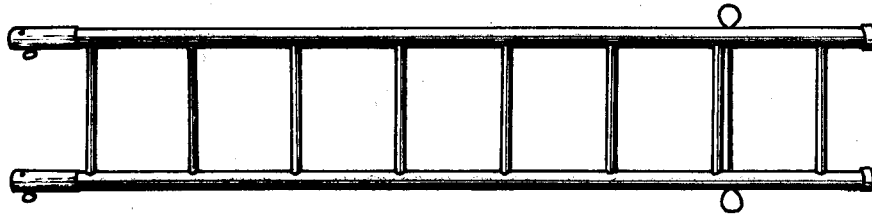

8.8 Platform

Constructed of reinforced synthetic material or wood. It is attached to a support to position a worker.

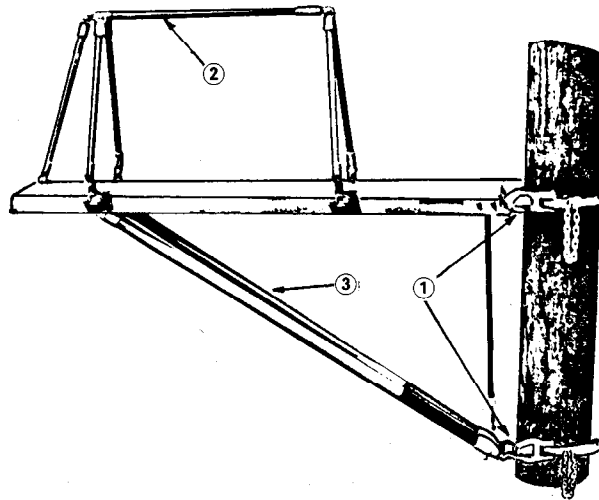

- ① Chain binder
- ② Safety rail
- ③ Support arm

8.9 Platform Pivot Attachment

A metal accessory, fixed to a structure, that allows a platform or beam to be moved into a working position.

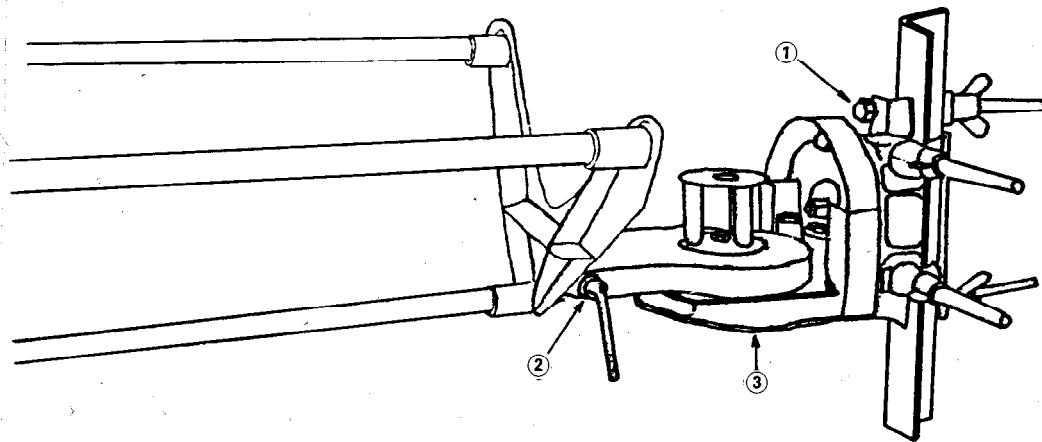

- ① Tower-type saddle
- ② Platform pivot
- ③ Adjustable mounting-bracket

8.10 Seat

Suspended from a girder saddle to position a worker.

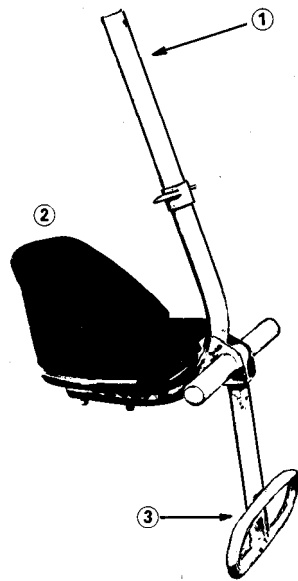

- ① Support pole (stick)
- ② Seat
- ③ Foot-rest

8.11 Spliced Ladder

Constructed of sections made of metal or synthetic material spliced together.

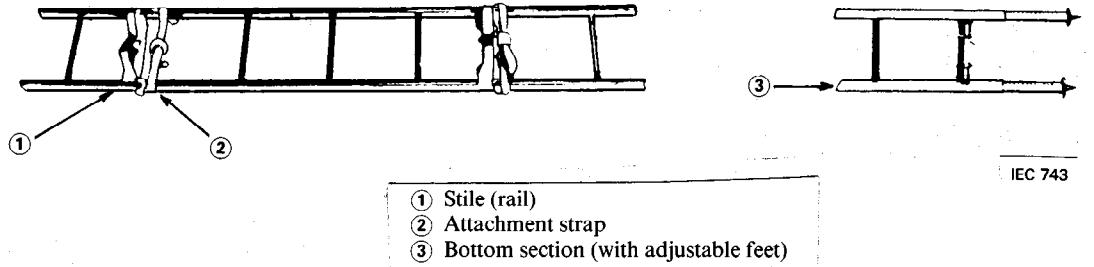

8.12 Triangular Beam

Constructed of insulating tubes and attached to a structure with saddles and rope blocks. It is used to position a worker.

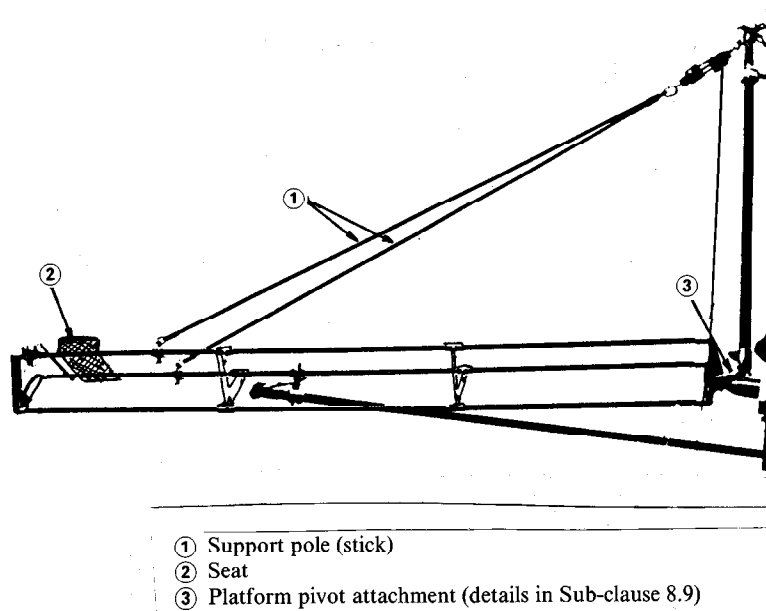

9. Handling and Anchoring Equipment

9.1 Rope, Sling, Rope Block, and Accessories

9.1.1 Block

Used in rigging to guide a rope or support a load.

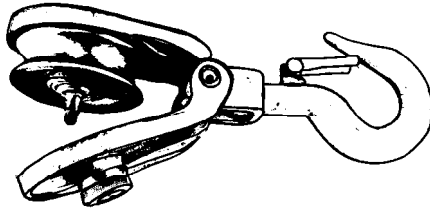

Snatch block

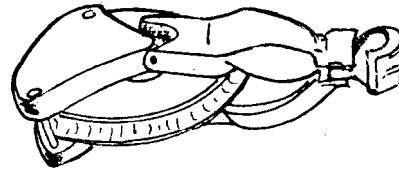

Running block

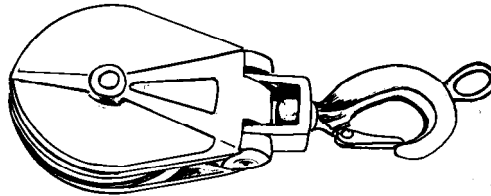

Block with a gripping ring on the hook

9.1.2 Rope

Made of insulating or non-insulating material.

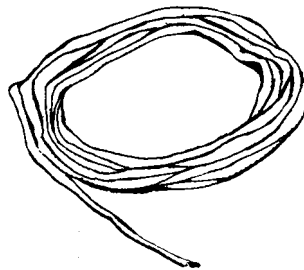

9.1.3 Rope Block

Device used with rope for handling, lifting, or rigging operation.

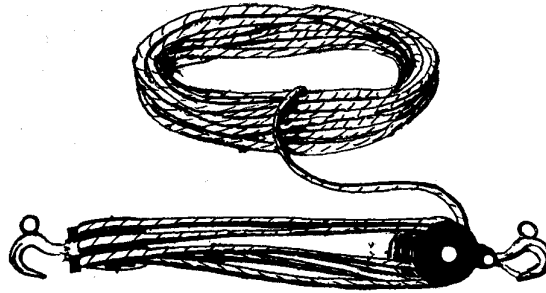

9.1.4 Sling

A rigging and handling accessory.



Double-eye type



Endless type

9.2 Yokes and Accessories

9.2.1 Anchor Clamp Bracket

Used when relieving mechanical tension at a dead-end string.

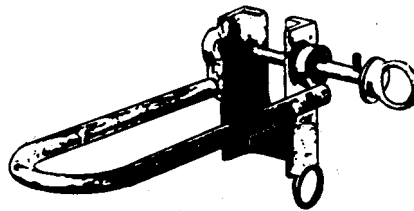

9.2.2 Lifting Yoke

Usually made of metal, used in lifting.

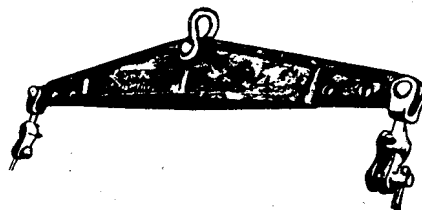

9.2.3 Tool Yoke

A metal tool used with strain carriers to relieve mechanical tension on insulators.

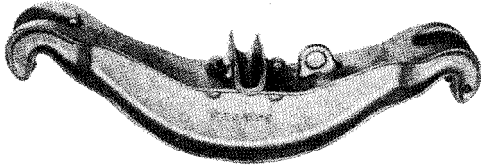

Double stick yoke

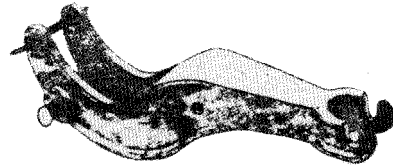

Single stick yoke

9.2.4 Tower Arm Yoke

A metal tool fixed to a tower to provide an attachment for lift sticks.

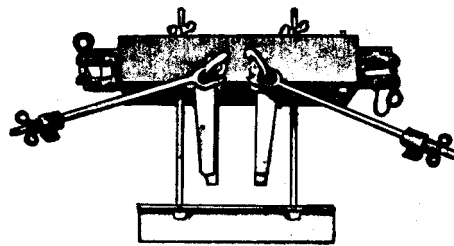

9.2.5 Stirrup, Stick Support

A metal accessory fitted to a support stick to provide a point of attachment.

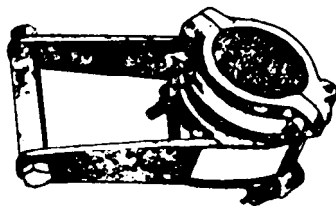

Rigid stirrup

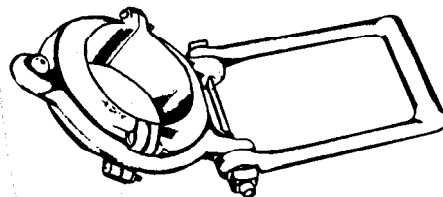

Swivel stirrup

9.3 Gin

9.3.1 Assembly, Gin

Assemblies used on structures or supports to handle various pieces of equipment.

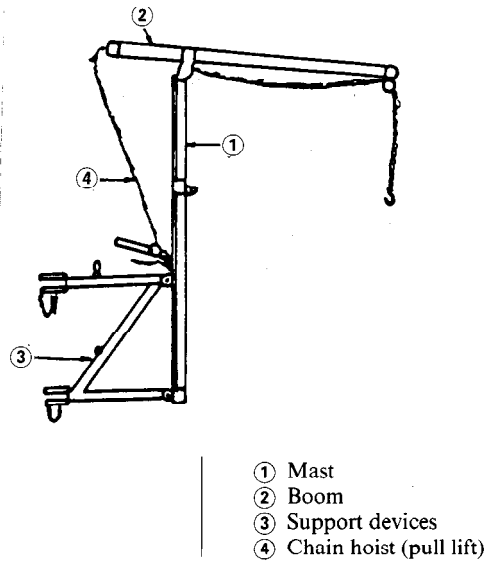

Type A

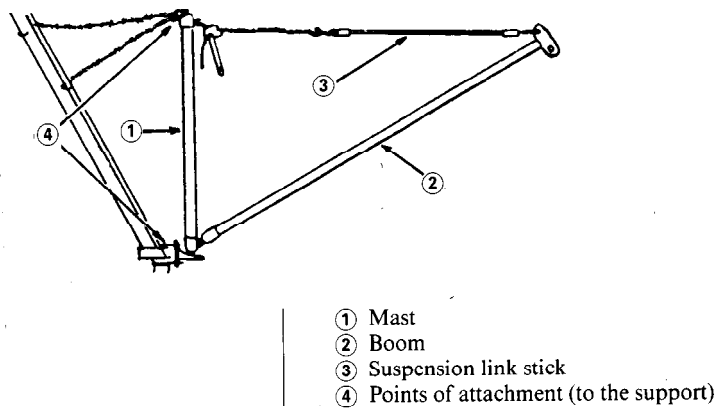

Type B

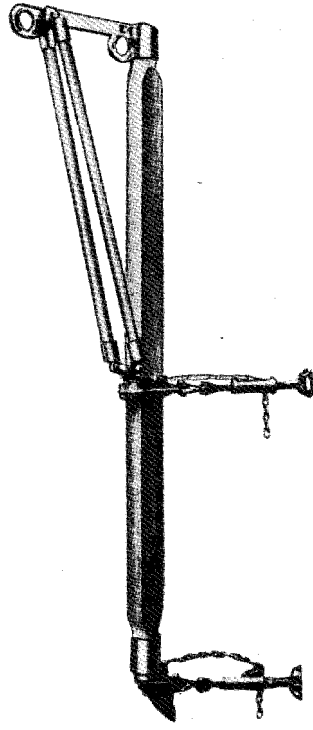

Type C

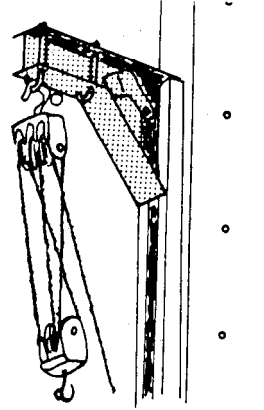

Type D

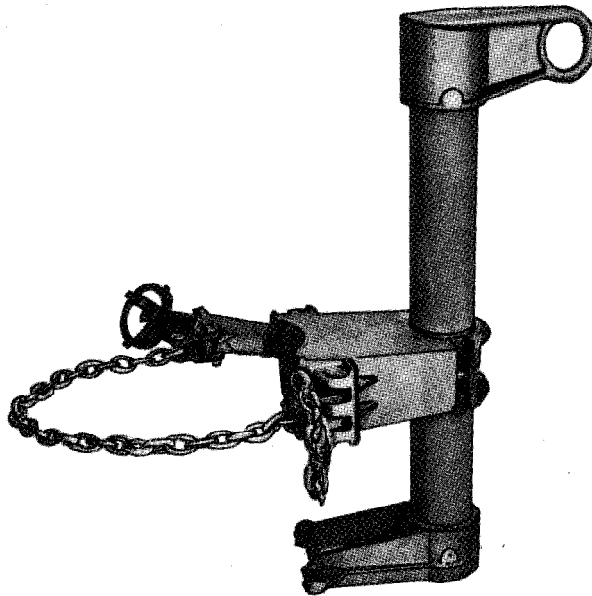

Type E

9.3.2 Auxiliary Arm

A pole assembly used a temporary support for conductors or bypass cables.

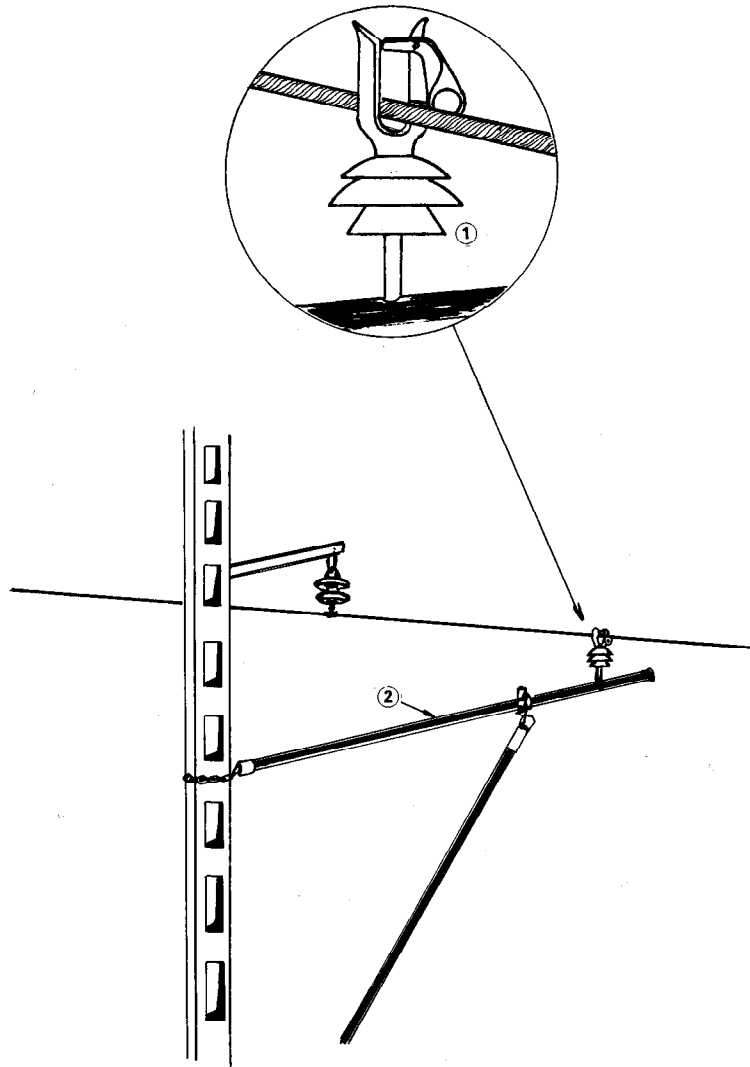

- ① Insulator with mechanical wire holder
- ② Auxiliary arm

9.4 Saddles and Accessories

9.4.1 Block Saddle

A metal accessory attached to a tower member and used for securing ropes.

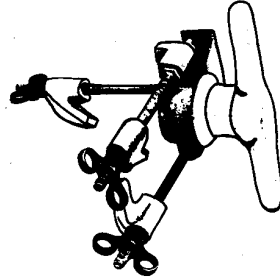

9.4.2 Chain Binder

A metal accessory used to secure pole saddles. It is used to attached various types of support equipment.

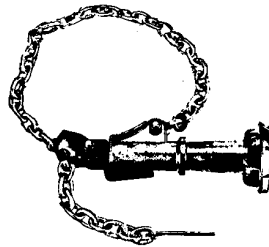

9.4.3 Chain Extension

Used to extend the length of a chain binder.

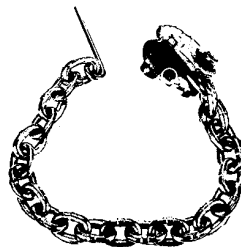

9.4.4 Double-Stick Clamp

Used to hold two stick together.

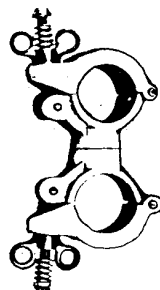

9.4.5 Lever Lift with Chain Binder

A metal accessory attached to a support and used with a support stick to raise or lower a conductor.

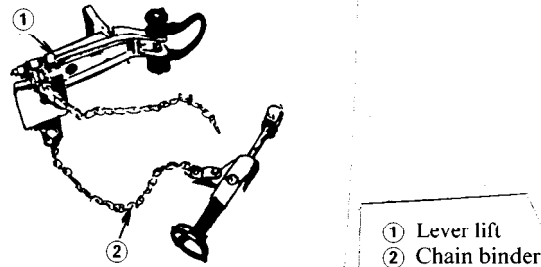

9.4.6 Locking Stick Clamp

Used with a support stick or saddle, to hold or guide a stick, includes locking device.

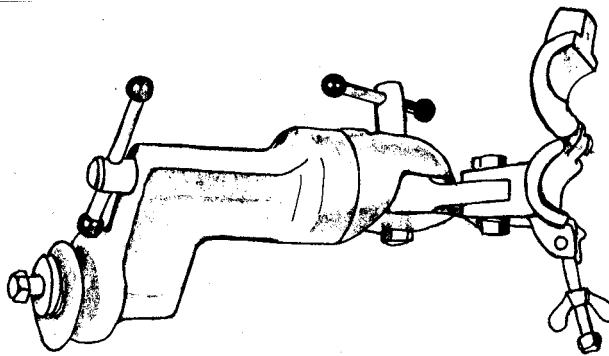

9.4.7 Rope-snubbing Bracket

A metal accessory attached to a support and used to provide a point of attachment for blocks or ropes.

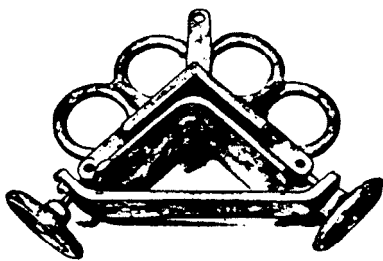

Tower-type bracket



Pole-type bracket

9.4.8 Saddle

A metal accessory to hold or guide a wire support stick.

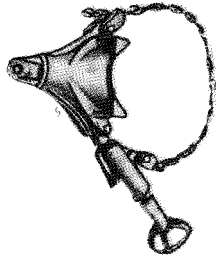

Pole-type saddle

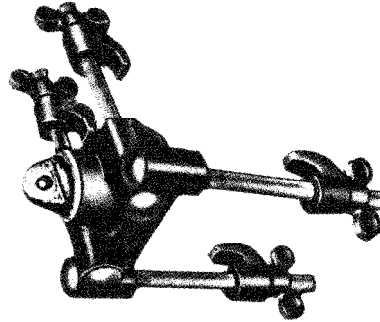

Tower-type saddle

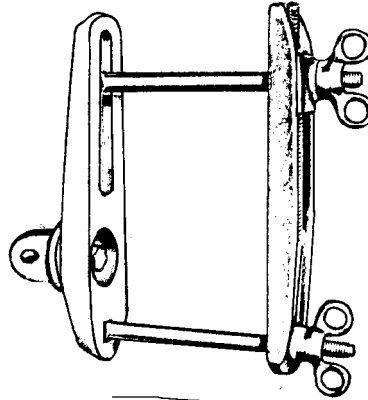

Crossarm-type saddle

9.4.9 Saddle Extension

Used with a stick saddle to increase clearance.

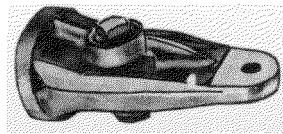

9.4.10 Stick Clamp

Used with a support stick or saddle to hold or guide a stick.

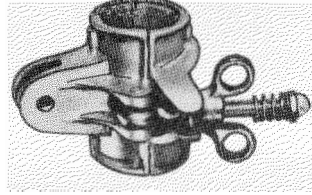

9.5 Miscellaneous

9.5.1 Antivibration Jumper Installing Tool

Composed of an insulating tube and metallic forks, is used with insulated ropes to handle an antivibration device.

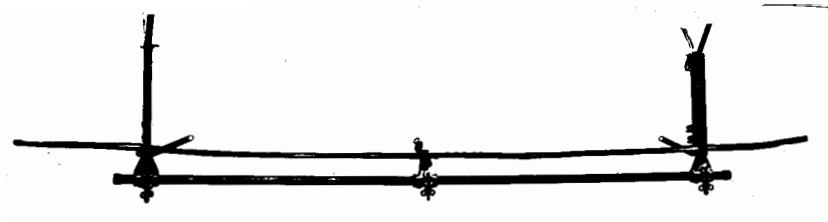

9.5.2 Automatic Wire Grip

Used as an anchor on a conductor.

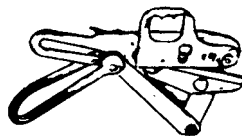

9.5.3 Insulator Cradle

Constructed of insulating tubes to facilitate the handling of an insulator string.

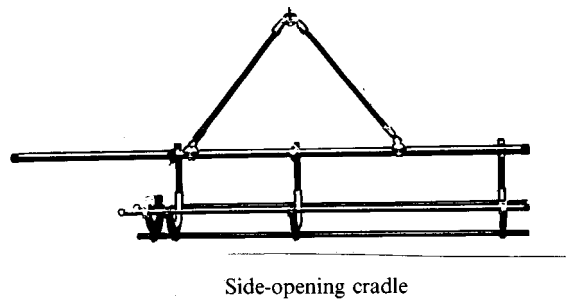
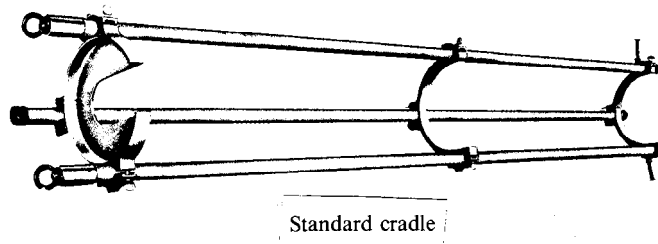
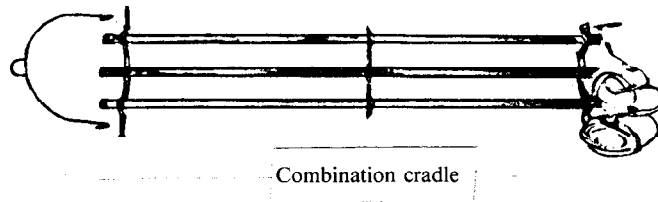

9.5.4 Insulator Fork

A synthetic or metal tool used to handle an insulator string.



9.5.5 Offset Eye

Used to provide a rigging eye when attached to the butt-ring of a stick.

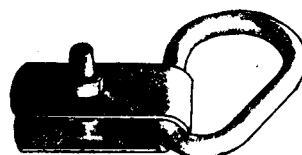

9.5.6 Trolley Stick Assembly

Assembly of sticks, used to position and remove suspension insulators.

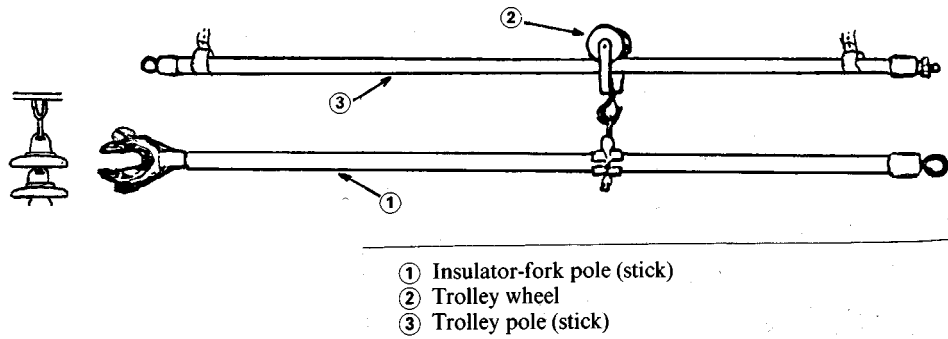

10. Measuring and Testing Equipment

10.1 Mechanical Measurements

10.1.1 Dynamometer

Used to measure the mechanical tension or variation of mechanical tension of a wire, in using calculator or conversion table.

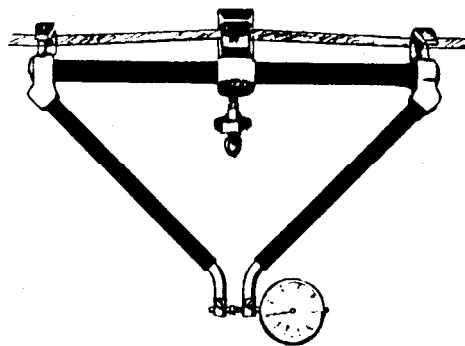

Type A

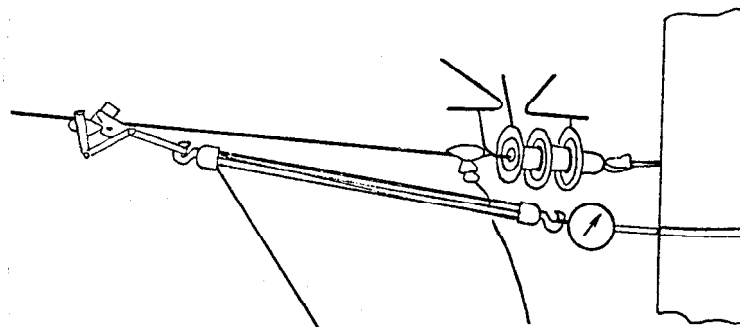

Type B

10.1.2 Gap Gauge

Made of insulating material and fitted to a universal hand stick to check and set the gap clearance of arcing horns.

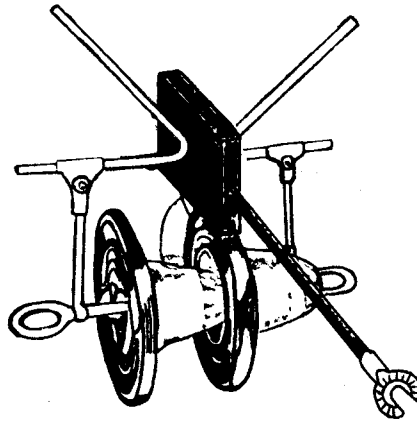

10.1.3 Measuring Pole or Stick

An insulating pole or stick used to measure lengths or clearances.



10.1.4 Wire Gauge

A universal hand-tool attachment used to measure the diameter of a wire.



10.2 Electrical Measurements

10.2.1 Live Line Tool Testers

Used to check conductivity of insulating tools and materials.

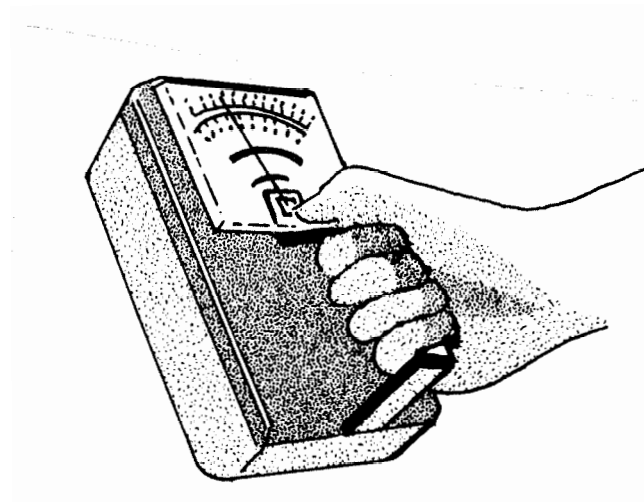
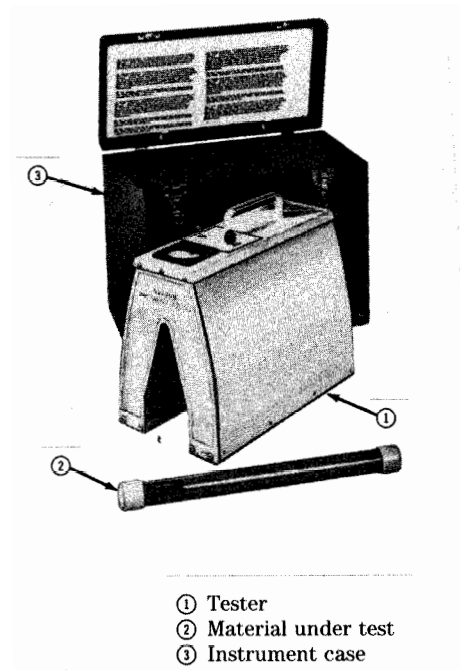

10.2.2 Phasing Tester

Attached to universal hand stick, used to check phasing and voltage.

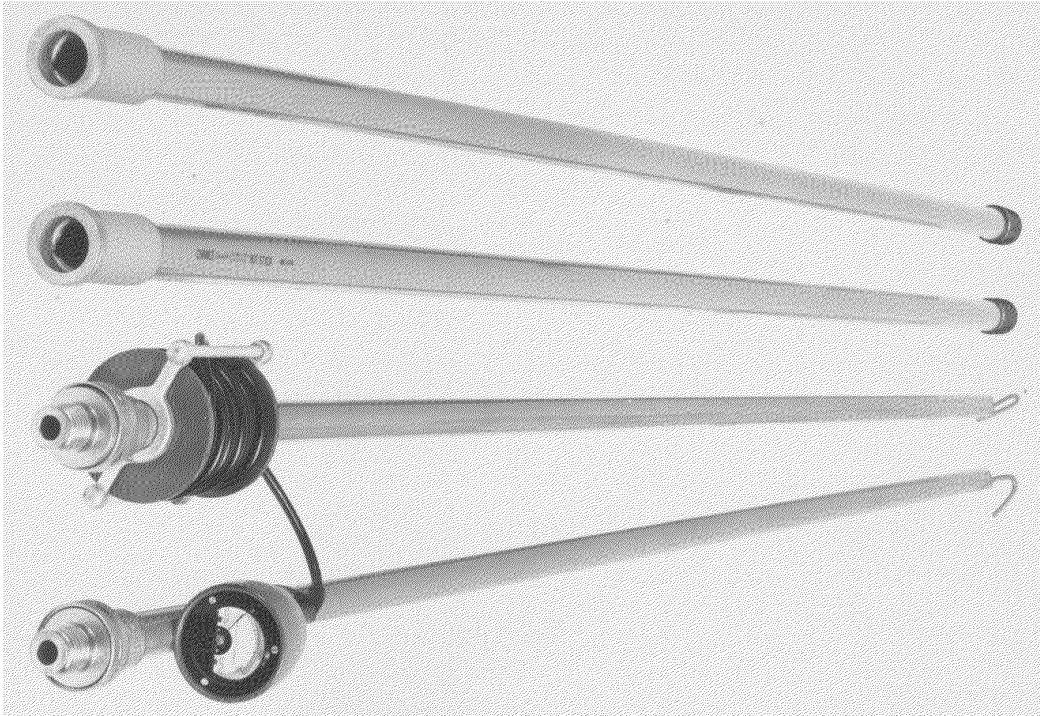

10.2.3 Voltage Detector

Used to detect the presence or absence of line voltage.

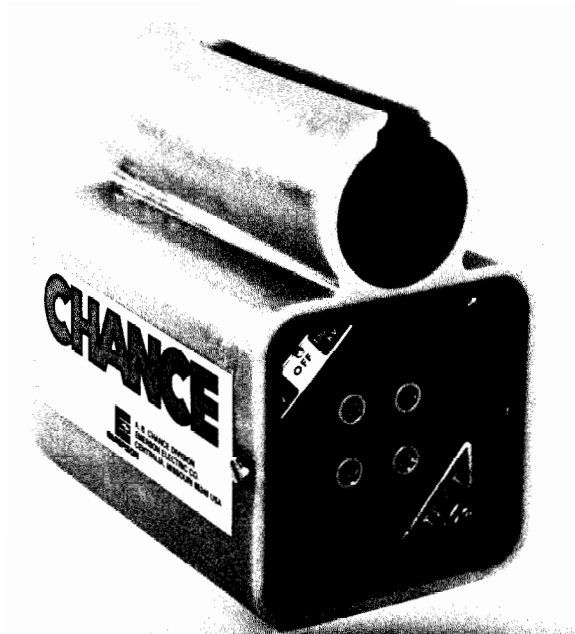

11. Hydraulic and Miscellaneous Equipment

11.1 Hydraulic Equipment

11.1.1 Hydraulic Compression Head

Used to compress various sleeves and connectors.

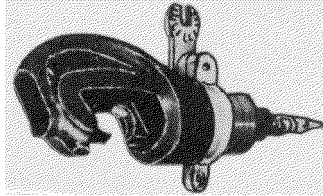

11.1.2 Hydraulic Cutter Head.

Used to cut wires when operated by a hydraulic pump.

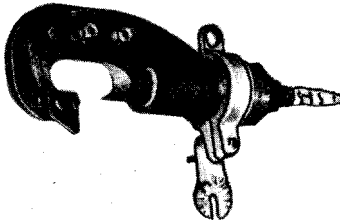

11.1.3 Hydraulic Hose

Flexible hose for hydraulic equipment.

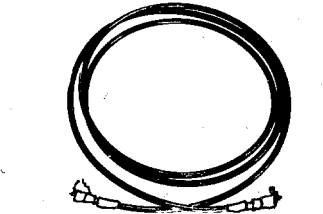

11.1.4 Hydraulic Pump

Used to generate hydraulic pressure for appropriate tools.

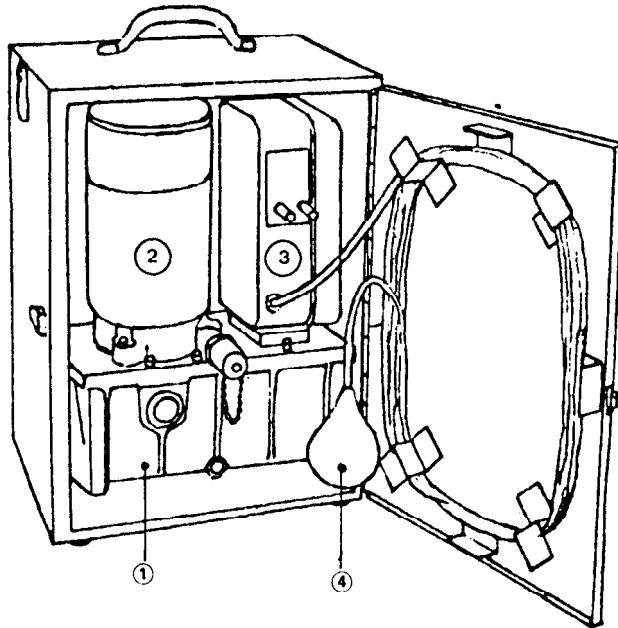

- ① Oil reservoir
- ② Motor pump
- ③ Connection box
- ④ Operating bulb

Electric motor pump

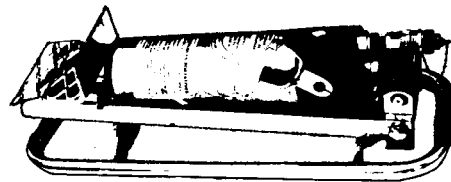

Foot pump

11.2 Miscellaneous Equipment

11.2.1 Armor Tape Winder

Used to apply metallic tape on wires.

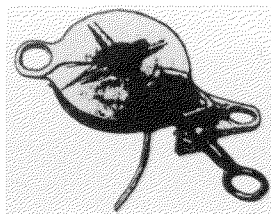

11.2.2 Hot Line Clamp

Used to connect a tap wire to a conductor.

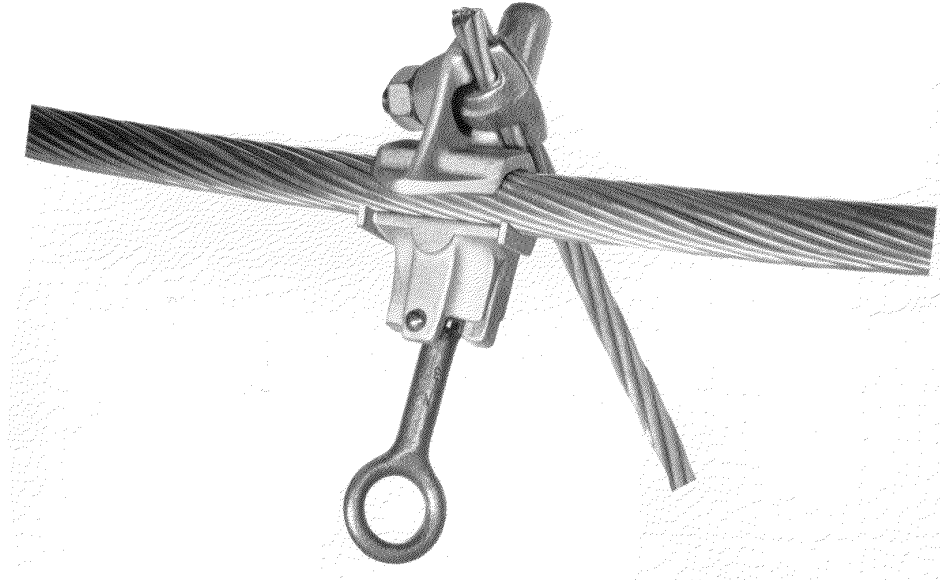

11.2.3 Insulating Blanket Clothes Pin

A clamp with a spring used to hold insulating blankets in position.

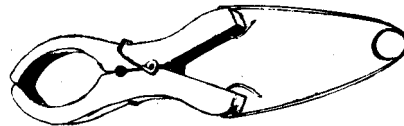

11.2.4 Insulating Hanger

A tube with a mechanical connector on one end and a metal hanger-bar on the other end, used temporarily when handling jumpers.

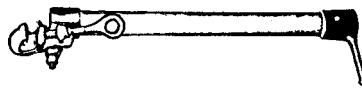

11.2.5 Tieback Connector J. M. Van Name

Used to secure the tail of a conductor.

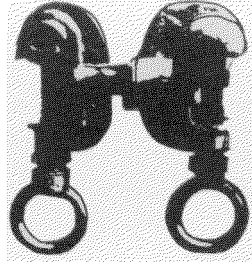

11.2.6 Tie Wire

Used to secure a wire to an insulator.



11.2.7 Tool Rack

Used to support poles in clear conditions.

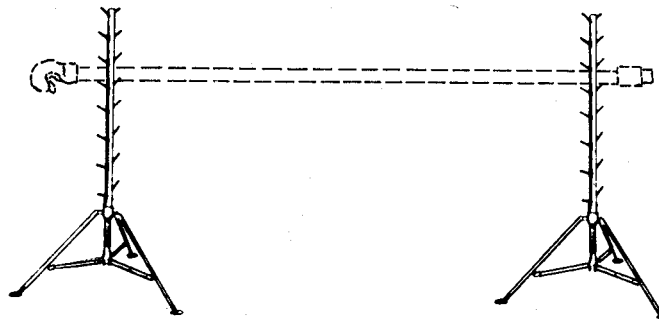

11.2.8 Wire Stripper

Used to strip insulation from conductors.

